

CHIARIMENTI: L'Antichizzazione è fatta manualmente e la tonalità dell'ottone può avere sfumature diverse da quelle delle foto. L'Antichizzazione fatta a mano non impedisce la naturale ossidazione di questo metallo che, esposto all'esterno, è soggetto all'azione degli eventi naturali. I nostri prodotti non sono autopulenti quindi, se vengono ricoperti da salsedine, devono essere puliti con i normali prodotti per pulizia dei metalli.

Svolta la procedura di pulitura, pian piano nel tempo riprodurranno la patina tipica dell'invecchiamento dell'ottone.

BA= Ottone brunito antichizzato
Laiton vieilli
Brass burnish finishing



AR - BA =

- OTTONE ANTICIZZATO PER INTERNI ED ESTERNI
- INDOOR AND OUTDOOR AGED BRASS
- LAITON POUR INTÉRIEUR ET L'EXTÉRIEUR
- ANTIKISIERTER MESSING FÜR DEN INNENRAUM UND AUßENRAUM

AR= Ottone antichizzato ramato
Aged brass copper-coloured
Laiton vieilli cuivré



.AC.AR.BA= OTTONE ANTICIZZATO / LAITON VIEILLI / AGED BRASS / ANTIKISIERTER MESSING - **non teme la salsedine / no salt corrosion**
Colore vetri / Couleurs verres / Glass colours - **.T** = trasparente - **.O** = opale

News



AC= Ottone antichizzato non ramato
Aged brass without copper color



NA= Colore argento antichizzato
Old silver color

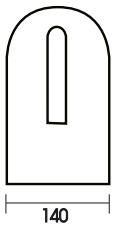

①
ART. 1820.T.AR
 H. 330 - Larg. 180

②
ART. 1821.T.NA
 H. 330 - Larg. 180



.AR.AC.BA.NA=
 OTTONE ANTICIZZATO PER ESTERNI E INTERNI
 AGED BRASS FOR OUTDOOR AND INDOOR
 LAITON VIEILLI
 ANTIKISIERTER MESSING

non teme la salsedine
no salt corrosion

Finitura ottone per interni
 Indoor brass finishes
.A.AR.AC.BA.D.NA

Colore vetri
 Couleurs verres
 Glass colours
.T = trasparente
.O = opale

CE IP 44 - E 27
 Max Watt 70



23/25 Watt
 1500 - 1600LM

Laser Cutting





ART. 1822.T.A

③
ART. 1822.T.AR
H. 330 - Larg. 180

④
ART. 1823.T.AR
H. 330 - Larg. 180

⑤
ART. 1823.T.D
H. 330 - Larg. 180





①

①
ART. 1950.O.NA
H. 455 - Larg. 190

.AR.AC.BA.NA=
OTTONE ANTICIZZATO PER ESTERNI E INTERNI
AGED BRASS FOR OUTDOOR AND INDOOR
L'AITON VIEILLI
ANTIKISIERTER MESSING

non teme la salsedine
no salt corrosion

Finitura ottone per Interni
Indoor brass finishes
.A.AR.AC.BA.D.NA

Colore vetri
Couleurs verres
Glass colours
.T = trasparente
.O = opale

CE IP 44 - E 27
Max Watt 70



23/25 Watt
1500 - 1600LM





②
ART. 1951.O.BA
 H. 455 - Larg. 190

③
ART. 1952.O.AR
 H. 285 - Larg. 180

.AR.AC.BA.NA=
 OTTONE ANTICIZZATO PER ESTERNI E INTERNI
 AGED BRASS FOR OUTDOOR AND INDOOR
 LAITON VIEILLI
 ANTIKISIERTER MESSING

non teme la salsedine
no salt corrosion

Finitura ottone per interni
 Indoor brass finishes
.A.AR.AC.BA.D.NA

Colore vetri
 Couleurs verres
 Glass colours
.T = trasparente
.O = opale

CE IP 44 - E 27

Light bulb icon Max Watt 70

mm 63
 mm 160
 Light bulb icon ① ②

23/25 Watt
 1500 - 1600LM

mm 63
 mm 140
 Light bulb icon ③

20/23 Watt





①



②



③

①
ART. 1850.O.AR
H. 480 - Larg. 200

②
ART. 1851.O.AR
H. 490 - Larg. 280

③
ART. 1852.T.AR
H. 310 - Larg. 190



.AR.AC.BA.NA=
OTTONE ANTICIZZATO PER ESTERNI E INTERNI
AGED BRASS FOR OUTDOOR AND INDOOR
LAITON VIEILLI
ANTIKISIERTER MESSING

**non teme la salsedine
no salt corrosion**

Finitura ottone per Interni
Indoor brass finishes
.A.AR.AC.BA.D.NA

Colore vetri
Couleurs verres
Glass colours
.T = trasparente
.O = opale

CE IP 44 - E 27

Max Watt 70

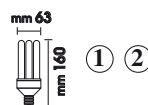

① ②

23/25 Watt
1500 - 1600LM

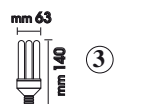

③

20/23 Watt



④
ART. 1853.T.AR
H. 360 - Larg. 240

⑤
ART. 1854.O.AR
H. 370 - Larg. 150

⑥
ART. 1855.O.AR
H. 890 - Larg. 150

.AR.AC.BA.NA=
OTTONE ANTICIZZATO PER ESTERNI E INTERNI
AGED BRASS FOR OUTDOOR AND INDOOR
LAITON VIEILLI
ANTIKISIERTER MESSING

non teme la salsedine
no salt corrosion

Finitura ottone per interni
Indoor brass finishes
.A.AR.AC.BA.D.NA

Colore vetri
Couleurs verres
Glass colours
.T = trasparente
.O = opale

CE IP 44 - E 27
Max Watt 70



20/23 Watt
1500 - 1600LM





④



⑤



④

ART. 1859.O.AR
H. 520 - Larg. 140

⑤

ART. 1860.O.AR
H. 1115 - Larg. 140



.AR.AC.BA=

OTTONE ANTICIZZATO
PER ESTERNI E INTERNI

AGED BRASS FOR
OUTDOOR AND INDOOR

LAITON VIEILLI
ANTIKISIERTER MESSING

non teme la salsedine
no salt corrosion

Finitura ottone per Interni
Indoor brass finishes
.AR.AC.BA

Colore vetri
Couleurs verres
Glass colours
.T = trasparente
.O = opale

CE IP 44 - E 27

Max Watt 70

mm 63
mm 140

23/25 Watt
1500 - 1600LM



①



②



③

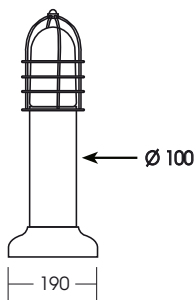

①
ART. 1856.O.AR
 H. 510 - Larg. 190

②
ART. 1857.O.AR
 H. 710 - Larg. 190

③
ART. 1858.O.AR
 H. 1230 - Larg. 190

.AR.AC.BA=

OTTONE ANTICIZZATO
 PER ESTERNI E INTERNI
 AGED BRASS FOR
 OUTDOOR AND INDOOR

LAITON VIEILLI
 ANTIKISIERTER MESSING

**non teme la salsedine
 no salt corrosion**

Finitura ottone per Interni
 Indoor brass finishes
.AR.AC.BA

Colore vetri
 Couleurs verres
 Glass colours
**.T = trasparente
 .O = opale**



CE IP 44 - E 27

Max Watt 70

mm 63



23/25 Watt

1500 - 1600LM



①
ART. 1890.O.AR
 H. 455 - Larg. 190

②
ART. 1891.O.AR
 H. 455 - Larg. 160

③
ART. 1892.T.AR
 H. 285 - Larg. 185



.AR.AC.BA.NA=
 OTTONE ANTICIZZATO PER ESTERNI E INTERNI
 AGED BRASS FOR OUTDOOR AND INDOOR
 LAITON VIEILLI
 ANTIKISIERTER MESSING

non teme la salsedine
no salt corrosion

Finitura ottone per interni
 Indoor brass finishes
.A.AR.AC.BA.D.NA

Colore vetri
 Couleurs verres
 Glass colours
.T = trasparente
.O = opale

CE IP 44 - E 27

Max Watt 70

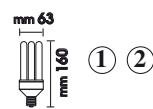

23/25 Watt
 1500 - 1600LM

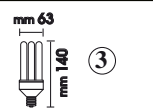

20/23 Watt



④



⑤

④

ART. 1893.O.AR
H. 320 - Larg. 145

⑤

ART. 1894.O.NA
H. 330 - Larg. 245

.AR.AC.BA.NA=
OTTONE ANTICIZZATO PER ESTERNI E INTERNI
AGED BRASS FOR OUTDOOR AND INDOOR
L'AITON VIEILLI
ANTIKISIERTER MESSING

non teme la salsedine
no salt corrosion

Finitura ottone per Interni
Indoor brass finishes
.A.AR.AC.BA.D.NA

Colore vetri
Couleurs verres
Glass colours
.T = trasparente
.O = opale

CE IP 44 - E 27

Max Watt 70



20/23 Watt





①



②



③



①
ART. 1870.O.AR
H. 490 - Larg. 210

②
ART. 1871.O.AR
H. 490 - Larg. 300

③
ART. 1872.T.AR
H. 310 - Larg. 200

.AR.AC.BA.NA=
OTTONE ANTICIZZATO PER ESTERNI E INTERNI
AGED BRASS FOR OUTDOOR AND INDOOR
LAITON VIEILLI
ANTIKISIERTER MESSING

**non teme la salsedine
no salt corrosion**

Finitura ottone per Interni
Indoor brass finishes
.A.AR.AC.BA.D.NA

Colore vetri
Couleurs verres
Glass colours
.T = trasparente
.O = opale

CE IP 44 - E 27
Max Watt 70

mm 63
mm 140 ① ②

23/25 Watt
1500 - 1600LM

mm 63
mm 140 ③

20/23 Watt



①

ART. 1873.O.AR
H. 510 - Larg. 190

②

ART. 1874.O.AR
H. 710 - Larg. 190

③

ART. 1875.O.AR
H. 1230 - Larg. 190

④

ART. 1876.O.AR
H. 520 - Larg. 140

⑤

ART. 1877.O.AR
H. 1115 - Larg. 140



CE IP 44 - E 27

Max Watt 70



23/25 Watt
1500 - 1600LM

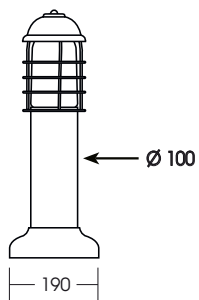

.AR.AC.BA=

OTTONE ANTICIZZATO
PER ESTERNI E INTERNI
AGED BRASS FOR
OUTDOOR AND INDOOR
LAITON VIEILLI
ANTIKISIERTER MESSING

**non teme la salsedine
no salt corrosion**

Finitura ottone per Interni
Indoor brass finishes
.AR.AC.BA

Colore vetri
Couleurs verres
Glass colours
.T = trasparente
.O = opale

④



⑤



①



②



③





- ①
ART. 1900.O.AR
H. 500 - Larg. 250
- ②
ART. 1901.O.AR
H. 480 - Larg. 310
- ③
ART. 1901.O.AC
H. 480 - Larg. 310
- ④
ART. 1902.T.NA
H. 310 - Larg. 245

.AR.AC.BA.NA=

OTTONE ANTICIZZATO
PER ESTERNI E INTERNI
AGED BRASS FOR
OUTDOOR AND INDOOR
LAITON VIEILLI
ANTIKISIERTER MESSING

**non teme la salsedine
no salt corrosion**

Finitura ottone per interni
Indoor brass finishes
.A.AR.AC.BA.D.NA

Colore vetri
Couleurs verres
Glass colours
.T = trasparente
.O = opale

CE IP 44 - E 27

Max Watt 70



① ② ③

23/25 Watt
1500 - 1600LM



④

20/23 Watt



①

ART. 1903.O.AR
H. 510 - Larg. 190

②

ART. 1904.O.AR
H. 710 - Larg. 190

③

ART. 1905.O.AR
H. 1230 - Larg. 190

④

ART. 1906.O.AR
H. 520 - Larg. 140

⑤

ART. 1907.O.AR
H. 1115 - Larg. 140



CE IP 44 - E 27

Max Watt 70



23/25 Watt
1500 - 1600LM

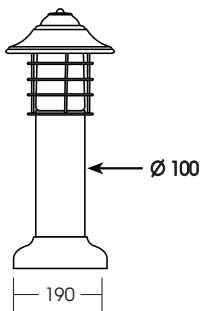

.AR.AC.BA=

OTTONE ANTICIZZATO
PER ESTERNI E INTERNI
AGED BRASS FOR
OUTDOOR AND INDOOR
LAITON VIEILLI
ANTIKISIERTER MESSING

**non teme la salsedine
no salt corrosion**

Finitura ottone per interni
Indoor brass finishes
.AR.AC.BA

Colore vetri
Couleurs verres
Glass colours
.T = trasparente
.O = opale

④



⑤



①



②



③



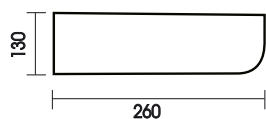

①
ART. 1840.O.AR
 H. 130 - Larg. 260

②
ART. 1841.O.AR
 H. 130 - Larg. 260



.AR.AC.BA.NA=

OTTONE ANTICIZZATO
 PER ESTERNI E INTERNI
 AGED BRASS FOR
 OUTDOOR AND INDOOR
 LAITON VIEILLI
 ANTIKISIERTER MESSING

**non teme la salsedine
 no salt corrosion**

Finitura ottone per Interni
 Indoor brass finishes
.A.AR.AC.BA.D.NA

Colore vetri
 Couleurs verres
 Glass colours
**.T = trasparente
 .O = opale**



①



②



①

CE IP 44 - E 27

Max Watt 70



20/23 Watt



①
ART. 1962.O.AR
 H. 1030 - Larg. 400

.AR.AC.BA.NA=
 OTTONE ANTICIZZATO PER ESTERNI E INTERNI
 AGED BRASS FOR OUTDOOR AND INDOOR
 LAITON VIEILLI
 ANTIKISIERTER MESSING

non teme la salsedine
no salt corrosion

Finitura ottone per Interni
 Indoor brass finishes
.A.AR.AC.BA.D.NA

Colore vetri
 Couleurs verres
 Glass colours
.T = trasparente
.O = opale



CE IP 44 - E 27
 Max Watt 70



23/25 Watt
 1500 - 1600LM

①



①
ART. 1970.O.AR
 H. 290 - Larg. 380

②
ART. 1971.O.AR
 H. 270 - Larg. 420

.AR.AC.BA.NA=
 OTTONE ANTICIZZATO PER ESTERNI E INTERNI
 AGED BRASS FOR OUTDOOR AND INDOOR
 LAITON VIEILLI
 ANTIKISIERTER MESSING

non teme la salsedine
no salt corrosion

Finitura ottone per Interni
 Indoor brass finishes
.A.AR.AC.BA.D.NA

Colore vetri
 Couleurs verres
 Glass colours
.T = trasparente
.O = opale

CE IP 44 - E 27

Max Watt 70



20/23 Watt





④



③



⑤



③
ART. 1972.O.AR
H. 870 - Ø 22

④
ART. 1973.O.AR
H. 300 - Larg. 220

⑤
ART. 1975.O.AR
H. 1165 - Larg. 750
IP 20

⑥
ART. 1974
2 luci / 2 light - IP 20



.AR.AC.BA.NA=
OTTONE ANTICIZZATO PER ESTERNI E INTERNI
AGED BRASS FOR OUTDOOR AND INDOOR
LAITON VIEILLI
ANTIKISIERTER MESSING

non teme la salsedine
no salt corrosion

Finitura ottone per Interni
Indoor brass finishes
.A.AR.AC.BA.D.NA

Colore vetri
Couleurs verres
Glass colours
.T = trasparente
.O = opale

CE IP 44 - E 27

Max Watt 70



20/23 Watt



①
ART. 1590.T.AR
 H. 310 - Larg. 500 - Ø 325

②
ART. 1595.T.BA
 H. 340 - Larg. 365

③
ART. 1591.T.AR
 H. 360 - Larg. 620
 Inclinazione cappello 45°



.AR.BA=
 OTTONE ANTICIZZATO
 LAITON VIEILLI
 AGED BRASS
 ANTIKISIERTER MESSING
non teme la salsedine
no salt corrosion

Colore vetri
 Couleurs verres
 Glass colours
.T = trasparente
.O = opale

CE IP 44 - E 27

Max Watt 75



20/23 Watt



④

④
ART. 1593.T.AR
 H. 330 - Ø 325 - IP 43



⑤

⑤
ART. 1594.T.AR
 H. 650 - Ø 325 - IP 43



⑥

ART. 1592.T.AR trasparente
ART. 1592.TO.AR opale



⑦

ART. 1592.TT.AR trasparente
ART. 1592.TTO.AR opale

⑦
ART. 1592.TT.AR
 H. 890 - Ø 325 - IP 43



Vetri disponibili in due forme diverse
 Glasses available in two different shapes



①
ART. 1720.T.AR
 H. 730 - Larg. 620 - Kg. 3,70

②
ART. 1721.T.AR
 H. 3080 - Larg. 650 - Kg. 17

③
ART. 1722.T.AR
 H. 3080 - Larg. 1250 - Kg. 20



.AR.BA=
 OTTONE ANTICHIZZATO
 LAITON VIEILLI
 AGED BRASS
 ANTIKISIERTER MESSING

**non teme la salsedine
 no salt corrosion**

Colore vetri
 Couleurs verres
 Glass colours
.T = trasparente
.O = opale

Palo IP 55 Lanterna IP 44
 Pole IP 55 Light IP 44
 Pieu IP 55 Lumiere IP 44

CE IP 44 - E 27

Max Watt 75



20/23 Watt



PIASTRA

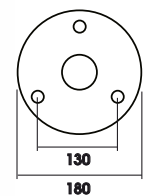
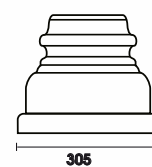

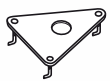

**Piastra
fissaggio
cod. APR8**

④
ART. 1722.T.BA
H. 3080 - Larg. 1250
Kg. 20

⑤
ART. 1723.T.AR
H. 3080 - Larg. 1130
Kg. 24



.AR.BA=
OTTONE ANTICIZZATO
LAITON VIEILLI
AGED BRASS
ANTIKISIERTER MESSING

**non teme la salsedine
no salt corrosion**

Colore vetri
Couleurs verres
Glass colours
.T = trasparente
.O = opale

CE IP 44 - E 27

Max Watt 75



20/23 Watt





①
ART. 1734.T.AR
 H. 600 - Larg. 520 - Kg. 2,70

②
ART. 1730.T.AR
 H. 730 - Larg. 620 - Kg. 3,90

③
ART. 1735.T.AR
 H. 155 - Larg. 560 - Kg. 8,80

④
ART. 1731.T.AR
 H. 3080 - Larg. 650 - Kg. 16,4



.AR.BA=
 OTTONE ANTICIZZATO
 LAITON VIEILLI
 AGED BRASS
 ANTIKISIERTER MESSING
non teme la salsedine
no salt corrosion

Colore vetri
 Couleurs verres
 Glass colours
.T = trasparente
.O = opale

Palo **IP 55** Lanterna **IP 44**
 Pole **IP 55** Light **IP 44**
 Pieu **IP 55** Lumiere **IP 44**

CE **IP 44 - E 27**

Light bulb icon Max Watt 75



20/23 Watt



PIASTRA

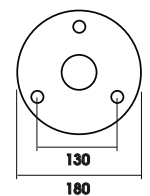
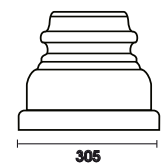

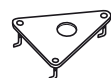

**Piastra
fissaggio
cod. APR8**

⑤
ART. 1732.T.AR
H. 3080 - Larg. 1250 - Kg. 19

⑥
ART. 1733.T.AR
H. 3080 - Larg. 1130 - Kg. 22

.AR.BA=
OTTONE ANTICIZZATO
L'AITON VIEILLI
AGED BRASS
ANTI-KISIERTER MESSING
non teme la salsedine
no salt corrosion

Colore vetri
Couleurs verres
Glass colours
.T = trasparente
.O = opale

Palo IP 55 Lanterna IP 44
Pole IP 55 Light IP 44
Pieu IP 55 Lumiere IP 44

CE IP 44 - E 27

💡 Max Watt 75

mm 63



20/23 Watt





①

ART. 1740.T.BA
 H. 500 - Larg. 300 - Ø 240mm
 Kg. 4



.AR.BA=
 OTTONE ANTICIZZATO
 LAITON VIEILLI
 AGED BRASS
 ANTIKISIERTER MESSING

non teme la salsedine
no salt corrosion

Colore vetri
 Couleurs verres
 Glass colours
.T = trasparente

CE IP 44 - E 27

Max Watt 70



20/23 Watt



②



③

Lampada da tavolo
da Interni IP 20
Indoor tablelamp IP 20



②

ART. 1742.T.AR
H. 1150 - Larg. 240 - Kg. 3,70

③

ART. 1743.T.AR
H. 500 - Larg. 240 - Kg. 3,60
IP 20



.AR.BA=
OTTONE ANTICIZZATO
LAITON VIEILLI
AGED BRASS
ANTIKISIERTER MESSING

**non teme la salsedine
no salt corrosion**

Colore vetri
Couleurs verres
Glass colours
.T = trasparente

CE IP 44 - E 27

Lightbulb icon Max Watt 70



20/23 Watt



①
ART. 1350.T.AR
H. 350 - Larg. 510

②
ART. 1353.T.AR
H. 350 - Larg. 365

③
ART. 1351.T.AR
H. 350 - Larg. 620



.AR.BA=
OTTONE ANTICIZZATO
LAITON VIEILLI
AGED BRASS
ANTIKISIERTER MESSING
non teme la salsedine
no salt corrosion

Colore vetri
Couleurs verres
Glass colours
.T = trasparente
.O = opale

CE IP 44 - E 27

Max Watt 75



20/23 Watt



④
ART. 1352.T.AR
H. 900 - IP 43



⑤
ART. 1356.T.AR
H. 670 - base Ø 110 - IP 43
heat Ø 300



ART. 1357.T.AR trasparente
ART. 1357.O.AR opale



ART. 1357.IT.AR trasparente
ART. 1357.ITO.AR opale



Vetri disponibili in due forme diverse
Glasses available in two different shapes

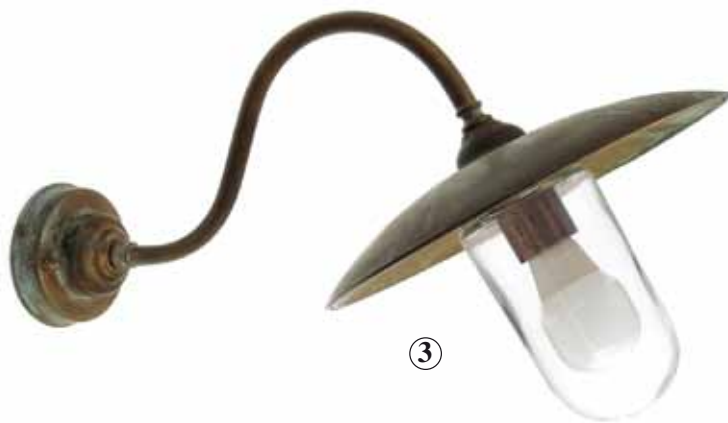

①
ART. 1340.T.BA
 H. 310 - Larg. 500 - Ø 300

②
ART. 1345.T.AR
 H. 340 - Larg. 360

③
ART. 1341.T.AR
 H. 340 - Larg. 540
 Inclinazione cappello 45°

.AR.BA=
 OTTONE ANTICIZZATO
 LAITON VIEILLI
 AGED BRASS
 ANTIKISIERTER MESSING

non teme la salsedine
no salt corrosion

Colore vetri
 Couleurs verres
 Glass colours
.T = trasparente
.O = opale

CE IP 44 - E 27

Max Watt 75



20/23 Watt





④



⑤



⑥



④

ART. 1343.T.AR
H. 320 - Ø 300 - IP 43

⑤

ART. 1344.T.AR
H. 640 - Ø 300 - IP 43

⑥

ART. 1342.T.AR
H. 900 - Ø 300 - IP 43





①
ART. 1361.T.AR
H. 300 - Larg. 470

②
ART. 1360.T.AR
H. 300 - Larg. 300

③
ART. 1365.T.AR
H. 330 - Larg. 510
Inclinazione cappello 45°



.AR.BA=
OTTONE ANTICIZZATO
LAITON VIEILLI
AGED BRASS
ANTIKISIERTER MESSING

non teme la salsedine
no salt corrosion

Colore vetri
Couleurs verres
Glass colours
.T = trasparente
.O = opale

CE IP 44 - E 27

Max Watt 75



20/23 Watt



④

④
ART. 1363.T.AR
 H. 290 - Ø 250 - IP 43



⑤

⑤
ART. 1364.T.AR
 H. 620 - Ø 250 - IP 43



⑥

⑥
ART. 1362.T.AR
 H. 850 - Ø 250 - IP 43





①
ART. 1330.T.BA
 H. 330 - Larg. 520

②
ART. 1335.T.AR
 H. 340 - Larg. 360

③
ART. 1331.T.AR
 H. 370 - Larg. 590
 Inclinazione cappello 45°



.AR.BA=
 OTTONE ANTICHIZZATO
 LAITON VIEILLI
 AGED BRASS
 ANTIKISIERTER MESSING

non teme la salsedine
no salt corrosion

Colore vetri
 Couleurs verres
 Glass colours
.T = trasparente
.O = opale

CE IP 44 - E 27

Max Watt 75



20/23 Watt



④

④
ART. 1333.T.AR
 H. 320 - Ø 320 - IP 43



⑤

⑤
ART. 1334.T.AR
 H. 630 - Ø 320 - IP 43



⑥

ART. 1332.T.AR trasparente
ART. 1332.TO.AR opale



⑦

ART. 1332.TT.AR trasparente
ART. 1332.TO.AR opale

⑦
ART. 1332.TT.AR
 H. 900 - Ø 320 - IP 43



Vetri disponibili in due forme diverse
 Glasses available in two different shapes

Lampara

.AR/.BA = OTTONE ANTICIZZATO PER ESTERNI
 LAITON VIEILLI POUR L'EXTÉRIEUR / OUTDOOR AGED BRASS
 ANTIKISIERTER MESSING FÜR DEN AUßENRAUM

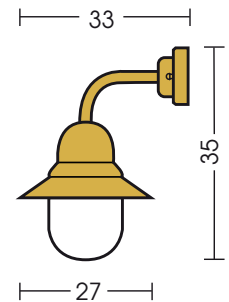

ART. 808

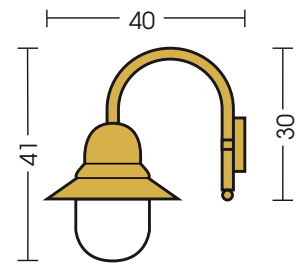

ART. 800

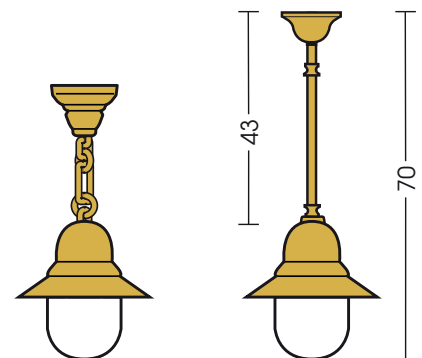

ART. 804

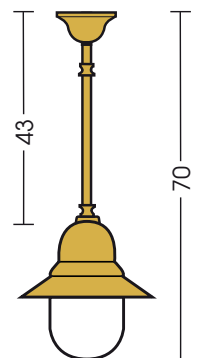

ART. 804F

CORPO: Ottone - CORPS: Laiton - BODY: Brass - KÖRPER: Messing
 DIFFUSORE: Policarbonato - DIFFUSEUR: Polycarbonate
 DIFFUSER: Polycarbonate - STRAHLER: Polykarbonat

AR/BA= no salt corrosion
(non teme la salsedine)

IP 44   E 27   Max Watt 60

Cavo sospensione neoprene nero per esterni

Finitura ottone
 Finition laiton
 Brass finishes

.AR.BA



ART. 803.BA
H 420 - Larg. 490



ART. 803.AR
H 420 - Larg. 490



ART. 804F.AR

Lampara

OTTONE ANTICHIZZATO PER ESTERNI
 LAITON VIEILLI POUR L'EXTÉRIEUR / OUTDOOR AGED BRASS
 ANTIKISIERTER MESSING FÜR DEN AUBENRAUM

AR= Ottone antichizzato ramato (per interni ed esterni)

CORPO: Ottone/Acciaio - CORPS: Laiton/Acier inoxydable

BODY: Brass/Stainless steel - KÖRPER: Messing/Edelstahl

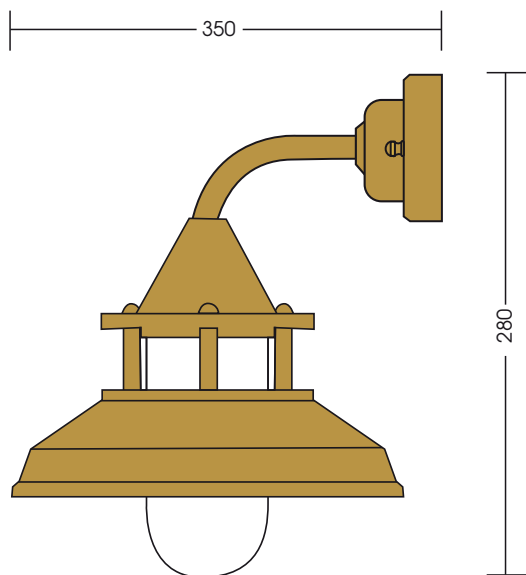

ART. 125.AR

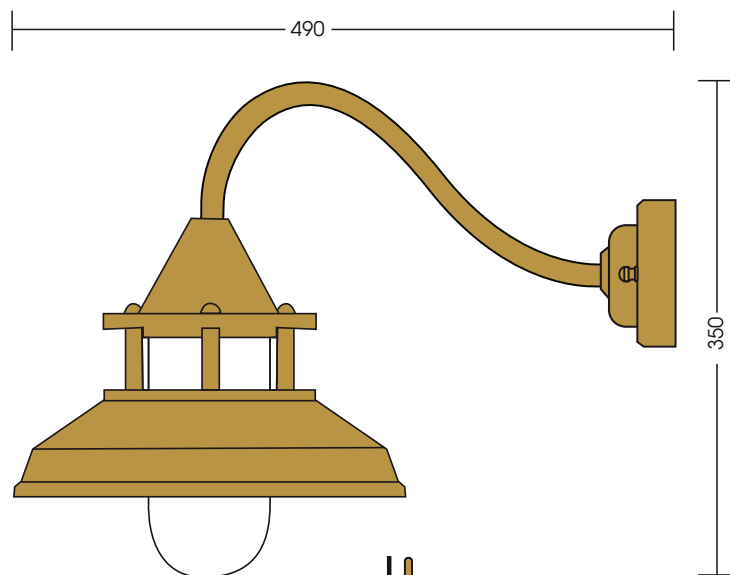

ART. 128.AR

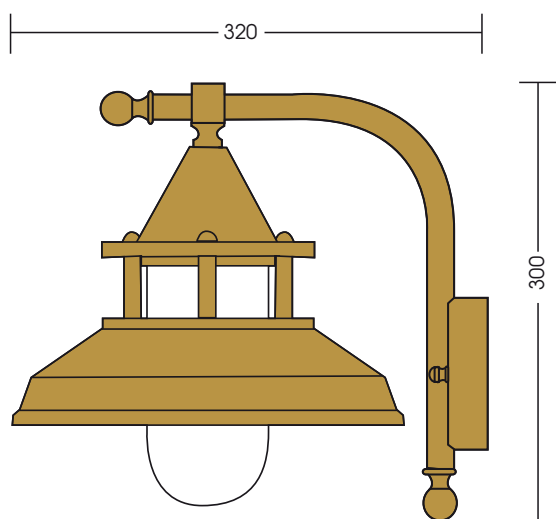

ART. 126.AR

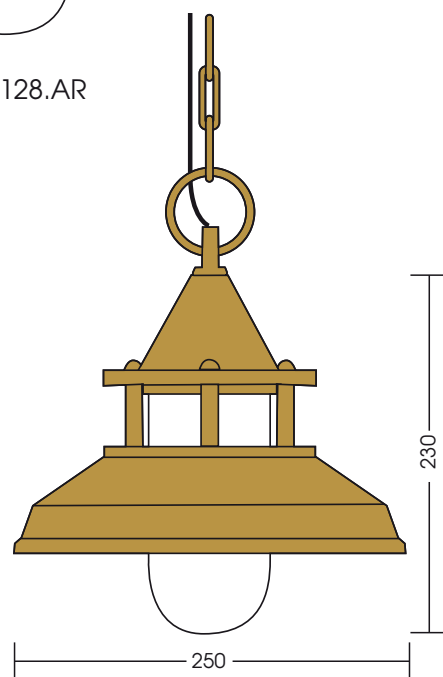

ART. 127.AR

IP 43  Max Watt 60

IP 44 



E 27



Max Watt 75



20/23 Watt

AR=
BA=

Ottone antichizzato

(non teme la salsedine)

Aged brass / Laiton vieilli

Cavo sospensione neoprene nero per esterni



ART. 125.AR



ART. 128.AR

OTTONE ANTICHIZZATO PER ESTERNI
 LAITON VIEILLI POUR L'EXTÉRIEUR / OUTDOOR AGED BRASS
 ANTIKISIERTER MESSING FÜR DEN AUBENRAUM

AR= Ottone antichizzato ramato (per interni ed esterni)

CORPO: Ottone/Acciaio - CORPS: Laiton/Acier inoxydable

BODY: Brass/Stainless steel - KÖRPER: Messing/Edelstahl

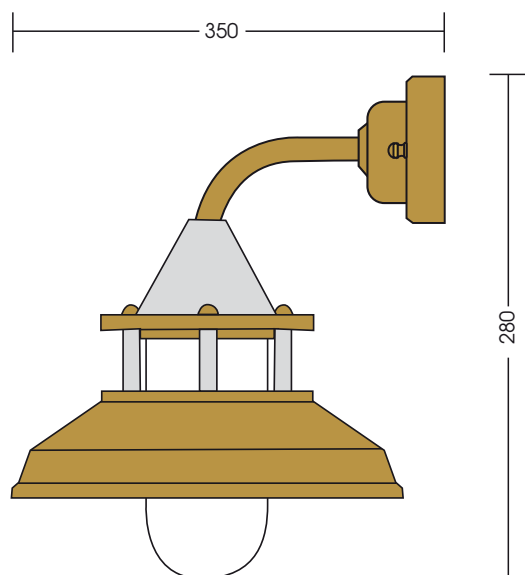

ART. 121.AR

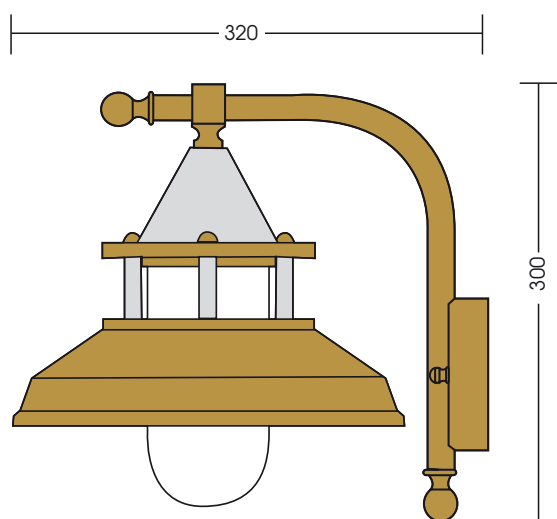

ART. 120.AR

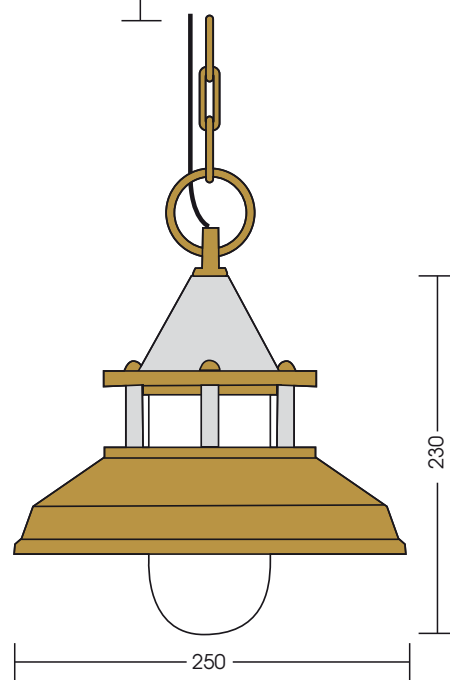

ART. 122.AR

IP 43  Max Watt 60

IP 44 



E 27



Max Watt 75



20/23 Watt

AR
BA =

Ottone antichizzato
(non teme la salsedine)
 Aged brass / Laiton vieilli

Cavo sospensione neoprene nero per esterni

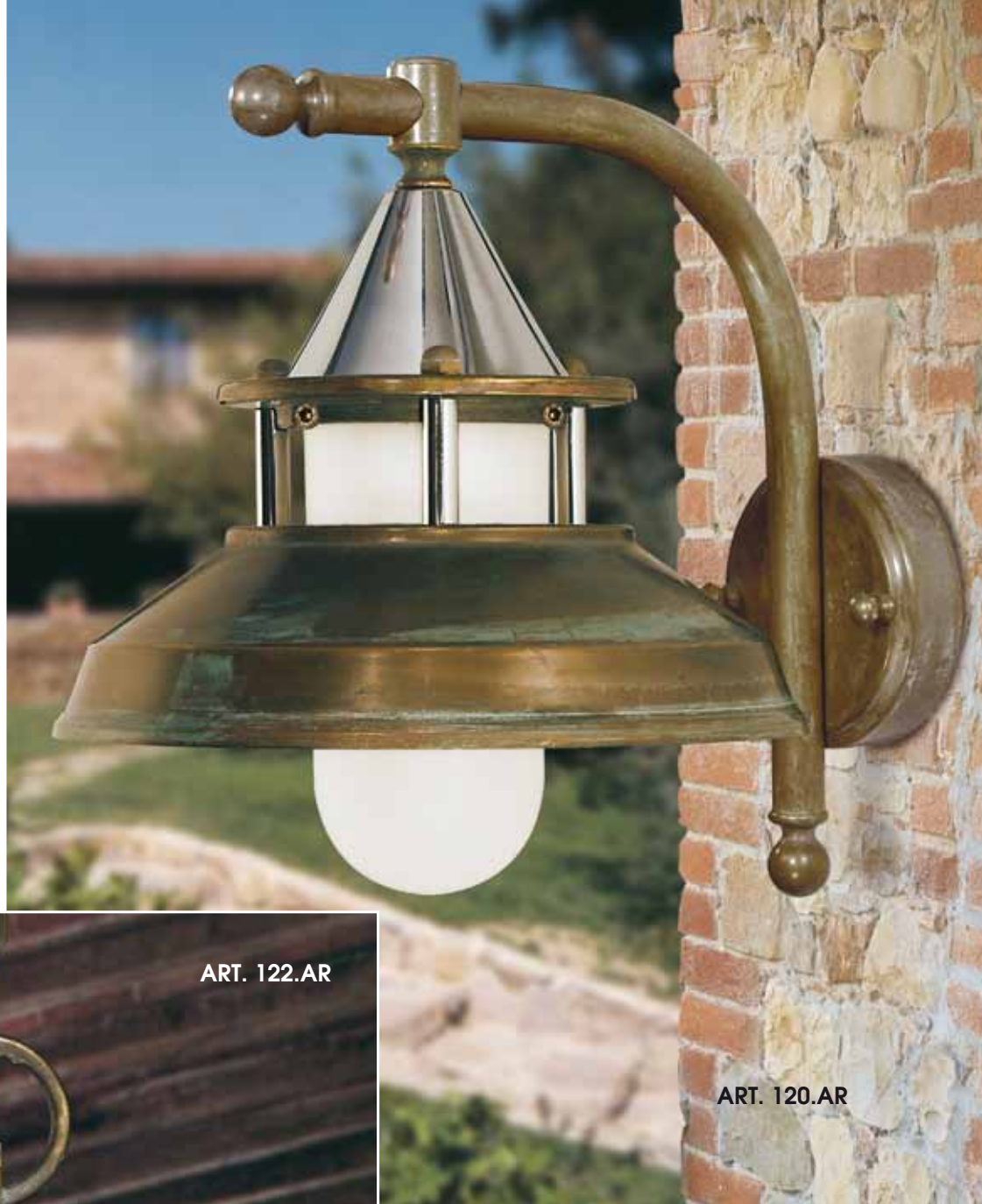

ART. 122.AR

ART. 120.AR



Casale

.A.AR.BA = OTTONE PER INTERNI / LAITON POUR INTÉRIEUR
INDOOR BRASS / GLÄNZENDER MESSING FÜR DEN INNENRAUM

AR.BA = OTTONE PER ESTERNI
LAITON POUR L'EXTÉRIEUR / OUTDOOR AGED BRASS
MESSING FÜR DEN AUBENRAUM

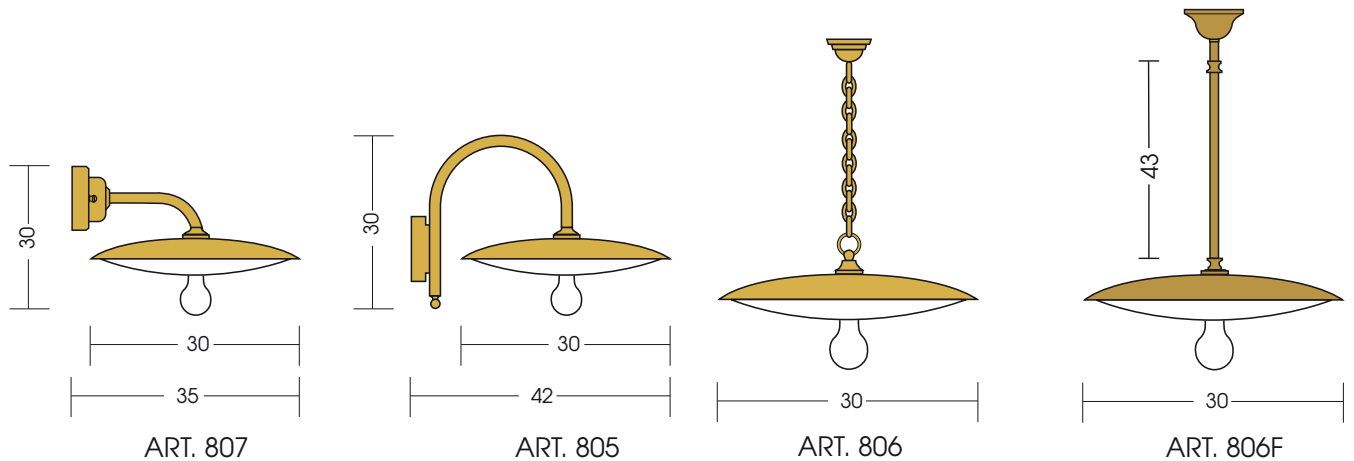

IP 23 E 27 Max Watt 100

Finitura ottone
Finition laiton
Brass finishes

.A.AR.BA

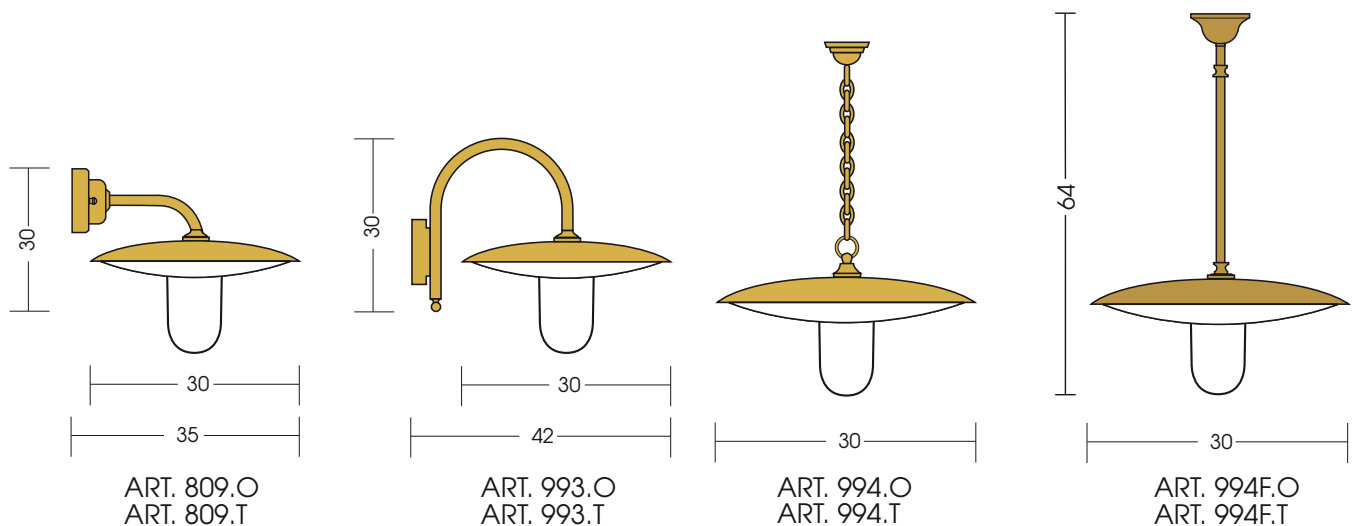

ART. 809/993 IP 44 E 27 Max Watt 75

ART. 994 IP 43 E 27 Max Watt 60

Finitura ottone
Finition laiton
Brass finishes

.A.AR.BA

ES: 993.O.AR

AR/BA= (non teme la salsedine)

O= opale. T= trasparente. **Cavo sospensione neoprene nero per esterni**

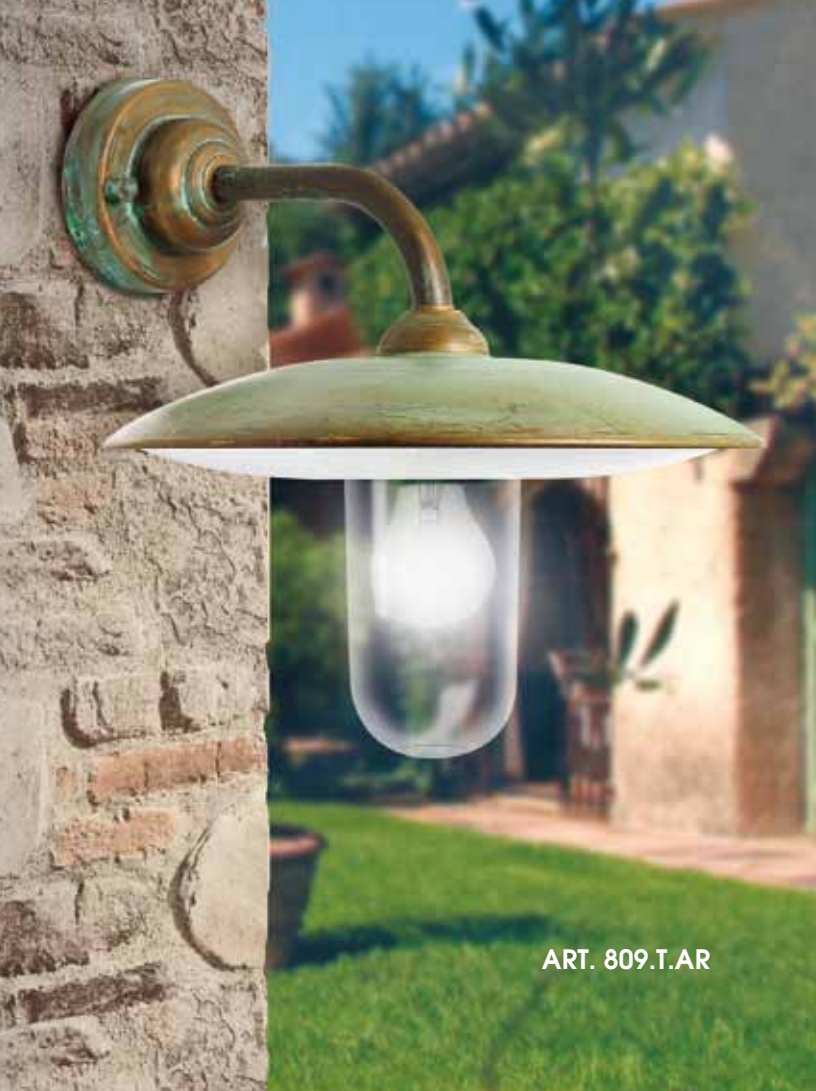

ART. 809.T.AR



ART. 994F.O.AR

Casale

Ocean

PLAFONIERE PER ESTERNI / LUMINAIRES POUR EXTÉRIEUR / OUTDOOR LIGHTING
DECKENLAMPE FÜR DEN AUBENRAUM

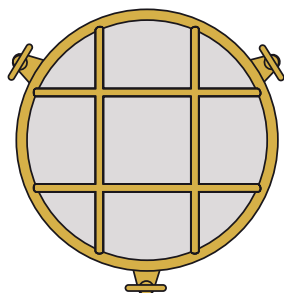

ART. 200.10
Larg. 210 - Prof. 100
Max Watt 60

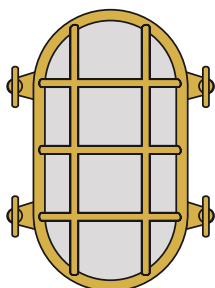

ART. 200.09
Larg. 150 - H. 225 - Prof. 110
Max Watt 60

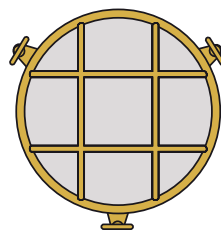

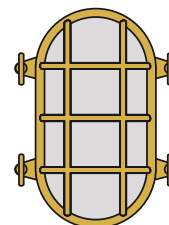

ART. 200.14
Larg. 175 - Prof. 115
Max Watt 40



ART. 200.15
Larg. 120 - H. 170 - Prof. 105
Max Watt 40

CORPO: Ottone - CORPS: Laiton - BODY: Brass - KÖRPER: Messing
VETRO: Opale o trasparente - VERRE: Blanc ou transparent
GLASS: White or trasparente - MILCHGLAS: oder transparentes Glas

 18 W Genie (200.09 e 200.10) - IP 44   E 27 
o simili

PLAFONIERE PER INTERNI / LUMINAIRES POUR INTÉRIEUR / INDOOR LIGHTING
DECKENLAMPE FÜR DEN INNENRAUM

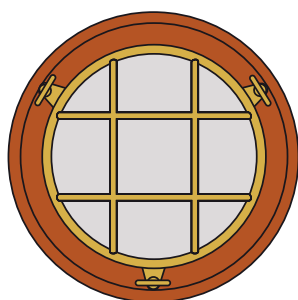

ART. 200.12
Larg. 280

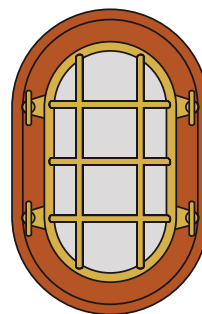

ART. 200.13
Larg. 190 - H. 295

CORPO: Ottone e legno - CORPS: Laiton et bois
BODY: Brass and wood - KÖRPER: Messing und holz
VETRO: Opale o trasparente - VERRE: Blanc ou transparent
GLASS: White or trasparente - MILCHGLAS: oder transparentes Glas

Con vetro trasparente: - Avec verre transparent: - White or trasparente glass:
Art. 200.09.T - 200.10.T - 200.14.T - 200.15.T

 18W Genie - IP 20  E 27  Max Watt 42
o simili

A richiesta finiture ottone .AR



ART. 200.13.T



ART. 200.12.T



ART. 200.09.AR



ART. 200.10.AR



AR = Ottone antichizzato ramato

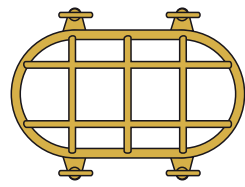
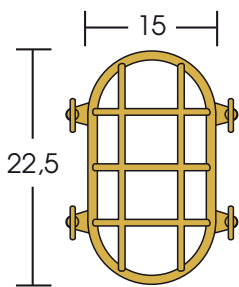

ART. 200.09
H. 22,5 - Larg. 15 - Prof. 11

Con vetro trasparente: 200.09.T
Avec verre transparent: 200.09.T
With glass transparent: 200.09.T

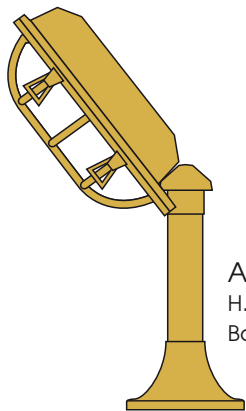

ART. 203
H. 42 - Larg. 27
Base Ø 14

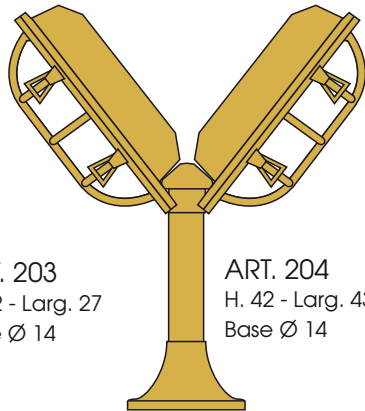

ART. 204
H. 42 - Larg. 43
Base Ø 14

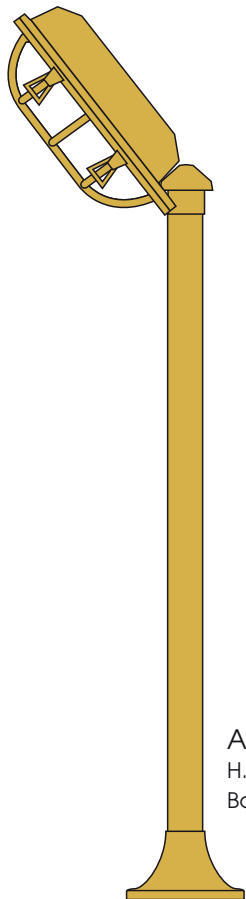

ART. 205
H. 105 - Larg. 27
Base Ø 14

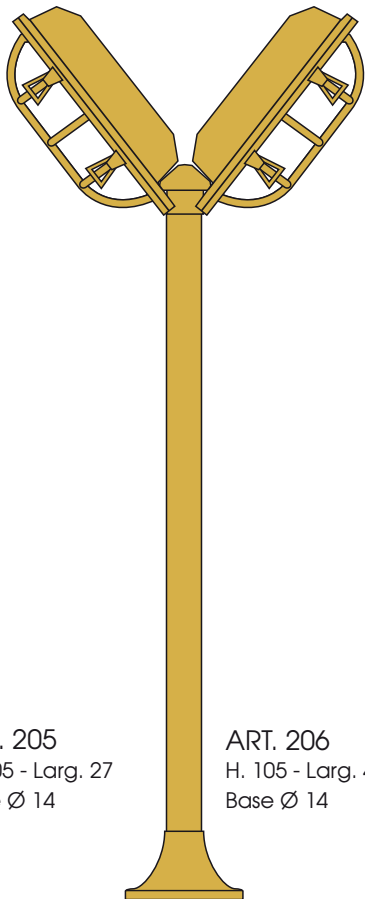

ART. 206
H. 105 - Larg. 43
Base Ø 14



ART. 200.09

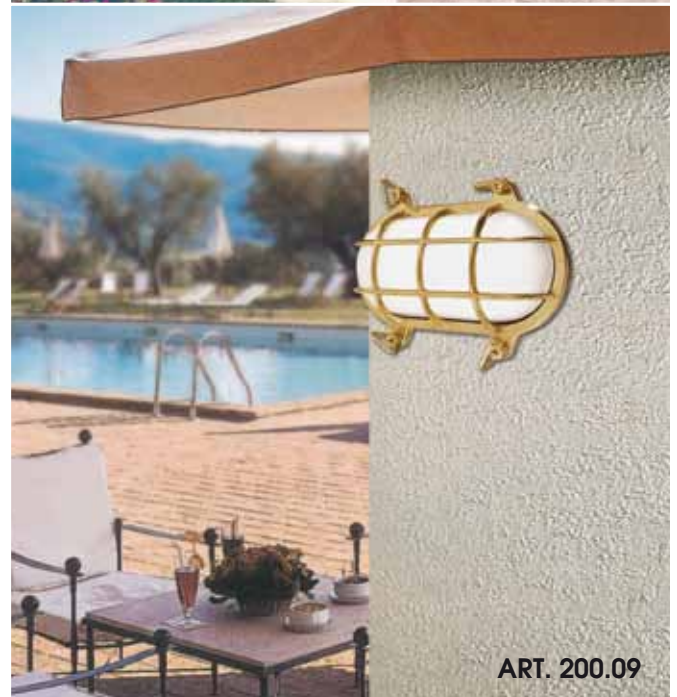

ART. 200.09

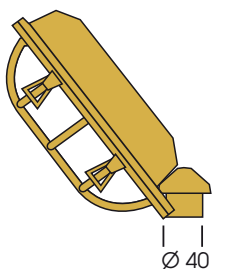

ART. 203B

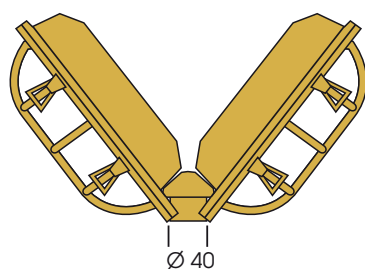

ART. 204B

Attacco per palo Ø 40 mm

CORPO: Ottone - CORPS: Laiton
BODY: Brass - KÖRPER: Messing
VETRO: Opale o trasparente
VERRE: Blanc ou transparent
GLASS: White or transparent
MILCHGLAS: Oder transparentes Glas

IP 44   E 27  60 W  18 W Genie
o simili



ART. 206

Con vetro trasparente: 200.10.T
 Avec verre transparent: 200.10.T
 With glass transparent: 200.10.T

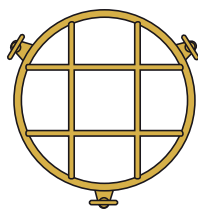

ART. 200.10
 Larg. 21

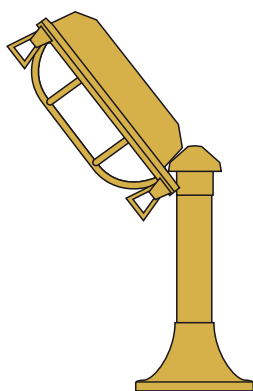

ART. 216
 H. 41 - Larg. 26
 Base Ø 14

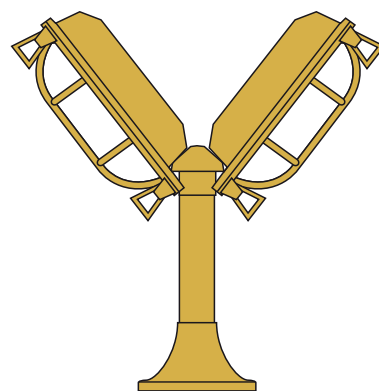

ART. 217
 H. 41 - Larg. 40
 Base Ø 14

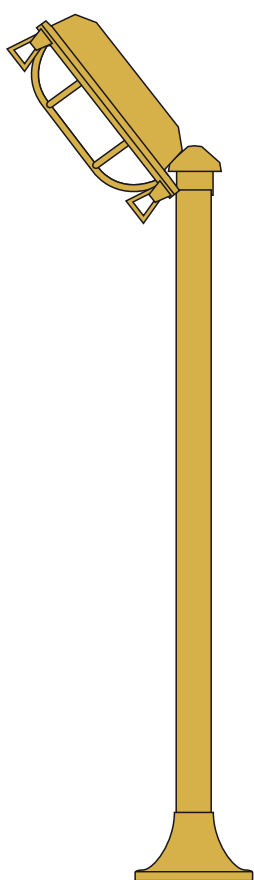

ART. 218
 H. 103 - Larg. 26
 Base Ø 14

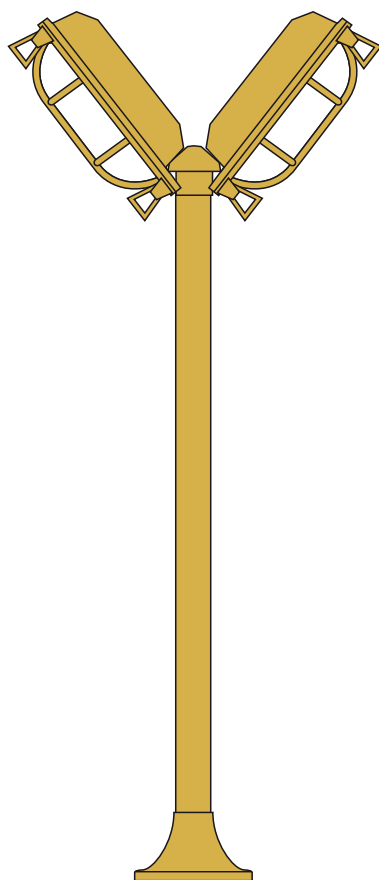

ART. 219
 H. 103 - Larg. 40
 Base Ø 14

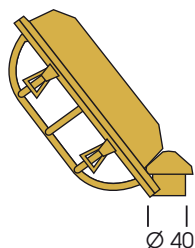

ART. 216B

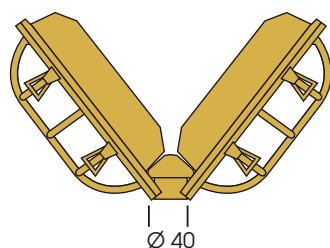

ART. 217B

Attacco per palo Ø 40 mm

CORPO: Ottone - CORPS: Laiton
 BODY: Brass - KÖRPER: Messing
 VETRO: Opale o trasparente
 VERRE: Blanc ou transparent
 GLASS: White or transparent
 MILCHGLAS: Oder transparentes Glas

IP 44   E 27  60 W  18 W Genie
 o simili



ART. 219

VETRO: Trasparente prismato
 VERRE: Transparent
 GLASS: Trasparent

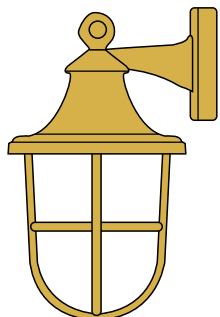

ART. 180

H. 27 - Prof. 21



15 Watt Plet

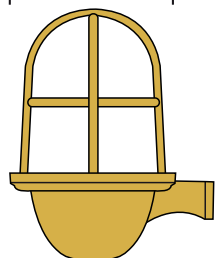

ART. 181

H. 21 - Larg. 17



15 Watt Genie

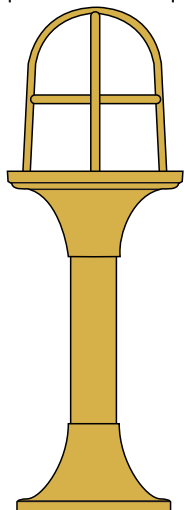

ART. 183

H. 40 - Base Ø 14



15 Watt Plet

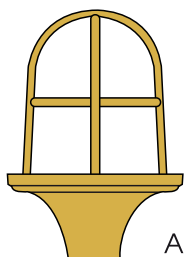

Ø 40

ART. 183B

Attacco per palo Ø 40 mm



15 Watt Plet

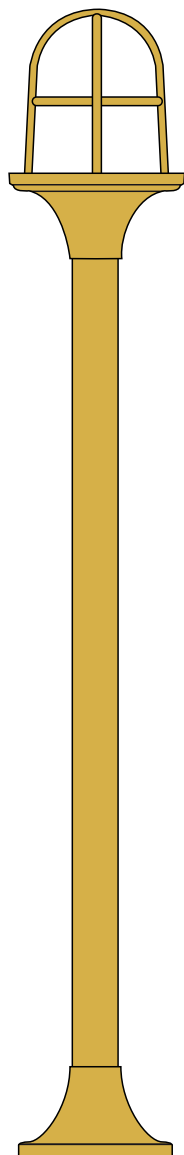

ART. 184

H. 103 - Base Ø 14



15 Watt Plet



ART. 180



ART. 181.AR

IP 44



E 27



60 W





ART. 183



ART. 184.AR



ART. 200.11

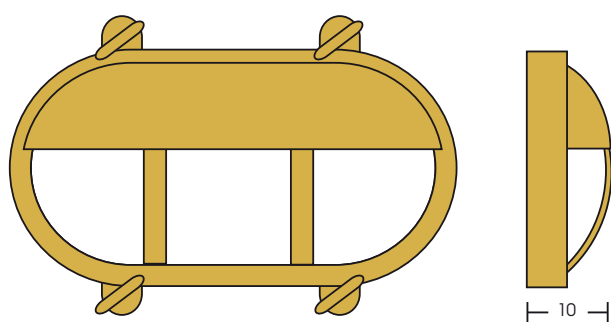

ART. 200.11
H. 10 - Larg. 20

Art. 200.11 - VETRO: Trasparente prismatico
VERRE: Transparent
GLASS: Transparent

E 27 - 40 Watt  18 W Genie  o simili

A richiesta finiture ottone .AR

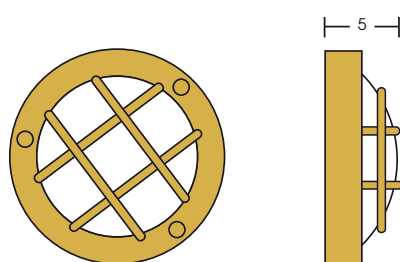

ART. 187.Gx53
 ART. 187.G9
 H. 5 - Prof. 5 - Ø 14
 G9 25 Watt

MICRO-LYNX F
 GX53= lampadina con dimensioni massime



esempio con lampadina sylvania 6W - Art. 25214

Art. 185/186/187/188 - VETRO: Opale liscio - VERRE: Blanc - GLASS: White

IP 44

A richiesta finiture ottone .AR



ART. 186



ART. 186.AR



ART. 188

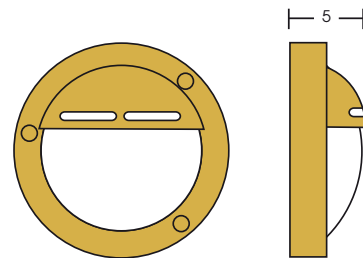

ART. 186.Gx53
ART. 186.G9
H. 5 - Prof. 5 - Ø 14
G9 25 Watt

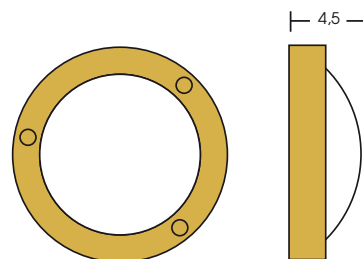

ART. 188.Gx53
ART. 188.G9
H. 4,5 - Prof. 4,5 - Ø 14
G9 25 Watt

MICRO-LYNX F
GX53= lampadina con dimensioni massime

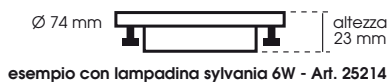

Art. 185/186/187/188 - VETRO: Opale liscio - VERRE: Blanc - GLASS: White

IP 44

A richiesta finiture ottone .AR



ART. 186



ART. 188



ART. 187

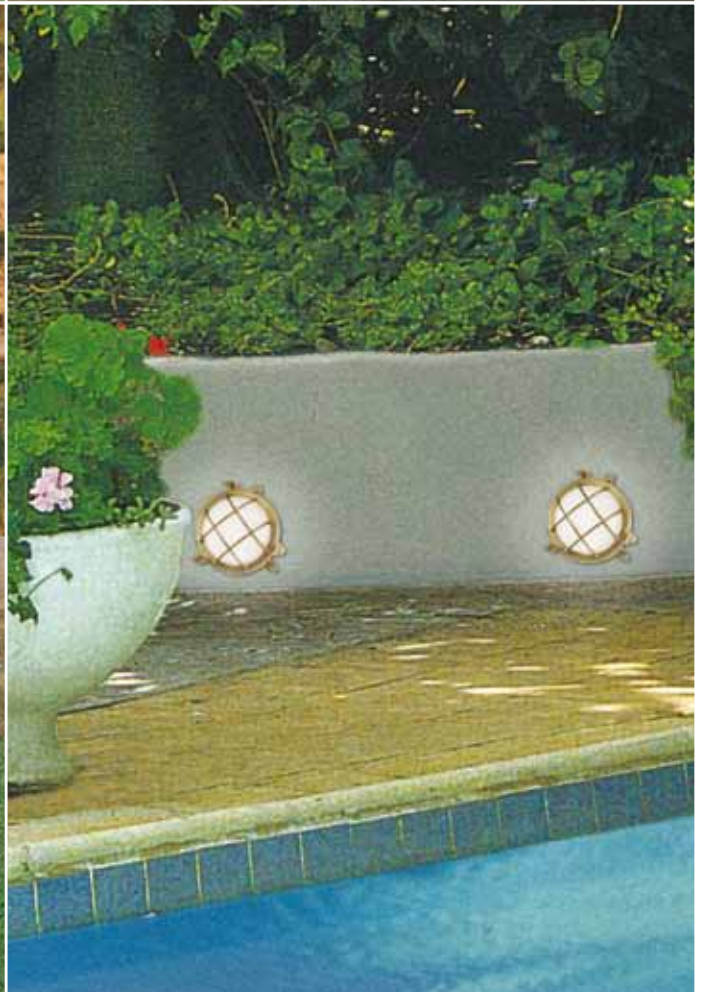

Ottone Cromato

OTTONE CROMATO PER INTERNI ED ESTERNI **(non teme la salsedine)**
 LAITON CHROMÉ POUR L'INTÉRIEUR ET L'EXTÉRIEUR / INDOOR AND OUTDOOR CHROMIUM-PLATED BRASS

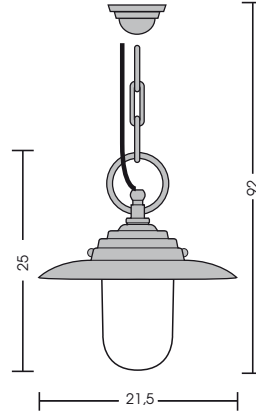

ART. 162.O.C
ART. 162.T.C

ART. 161.O.C
ART. 161.T.C



ART. 163.O.C
ART. 163.T.C

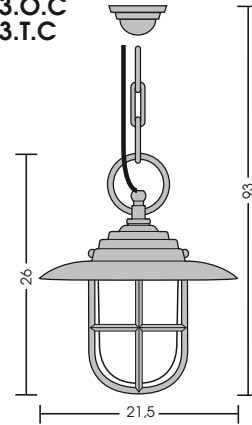

ART. 164.O.C
ART. 164.T.C

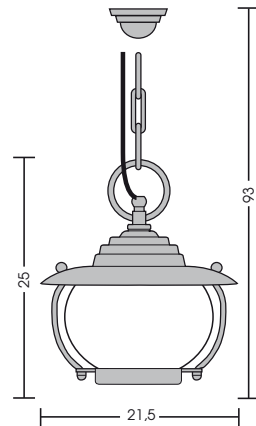

ART. 166.C

ART. 165.C

O= opale. T= trasparente. **C= ottone cromato satinato**

Art. 161 - 163 IP 44 Art. 162 - 164 - 166 IP 43 E 27 Max Watt 60 15/20 Watt

Cavo sospensione neoprene nero per esterni

Ottone Cromato

OTTONE CROMATO PER INTERNI ED ESTERNI **(non teme la salsedine)**
 LAITON CHROMÉ POUR L'INTÉRIEUR ET L'EXTÉRIEUR / INDOOR AND OUTDOOR CHROMIUM-PLATED BRASS

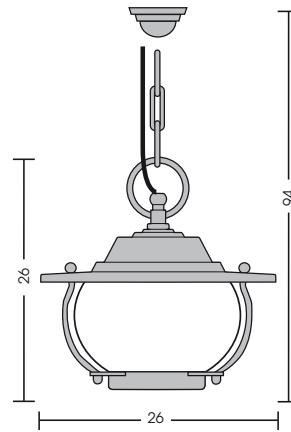

ART. 168.C



ART. 167.C



ART. 169.C

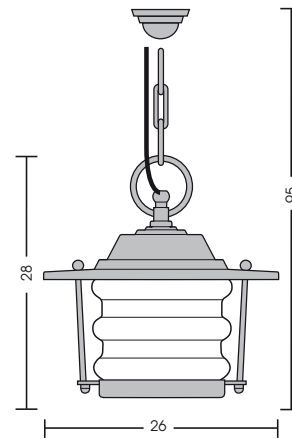

ART. 170.C



ART. 171.C

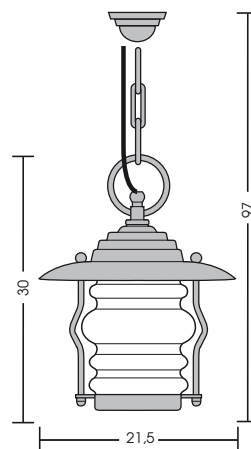

ART. 172.C

VETRO CHIUSO
 VERRE FERMÉ
 CLOSED GLASS
 GLAS GESCHLOSSEN

C= ottone cromato satinato

IP 43   E 27  Max Watt 60  15/20 Watt

Cavo sospensione neoprene nero per esterni

Ottone Cromato

OTTONE CROMATO PER INTERNI ED ESTERNI

(non teme la salsedine)

LAITON CHROMÉ POUR L'INTÉRIEUR ET L'EXTÉRIEUR
INDOOR AND OUTDOOR CHROMIUM-PLATED BRASS

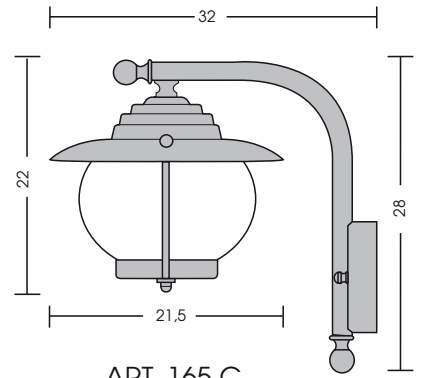

ART. 165.C

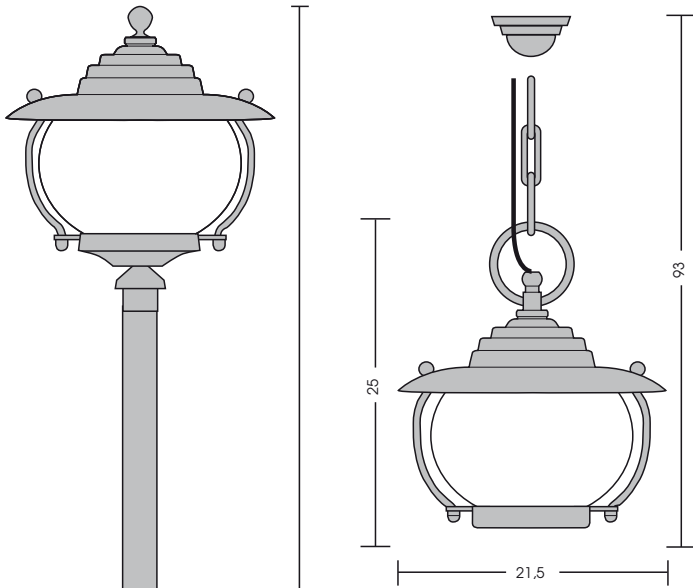

ART. 166.C



ART. 165.C

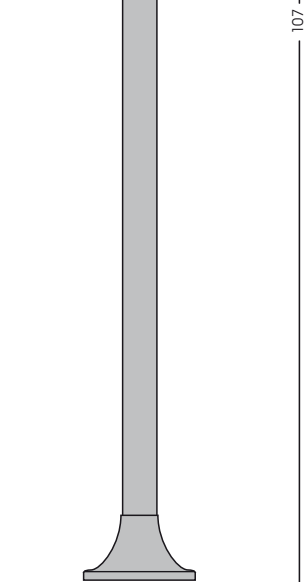

ART. 198.C

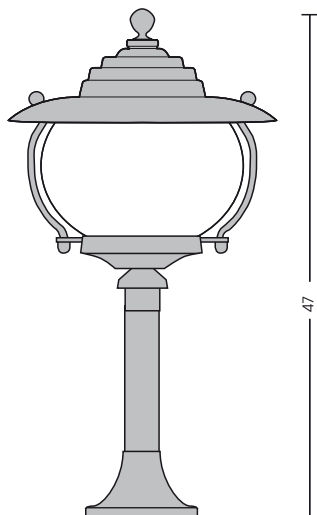

ART. 197.C

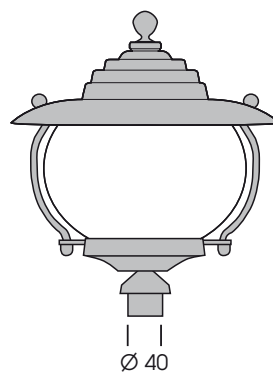

ART. 197B.C

Attacco per palo
Ø 40 mm (interno)

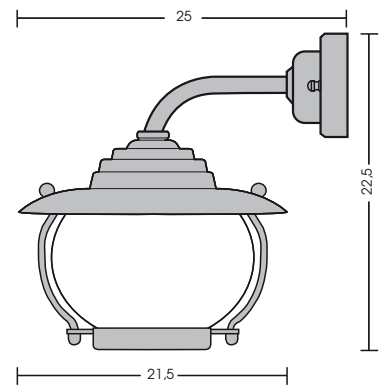

ART. 135.C

IP 44

C= ottone cromato satinato

IP 43 E 27 Max Watt 60 15/20 Watt



ART. 197.C



ART. 198.C

Ottone Cromato

OTTONE CROMATO PER INTERNI ED ESTERNI

(non teme la salsedine)

LAITON CHROMÉ POUR L'INTÉRIEUR ET L'EXTÉRIEUR
INDOOR AND OUTDOOR CHROMIUM-PLATED BRASS

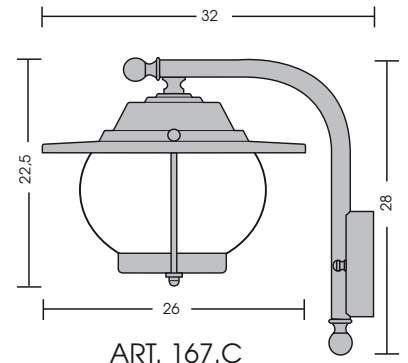

ART. 167.C

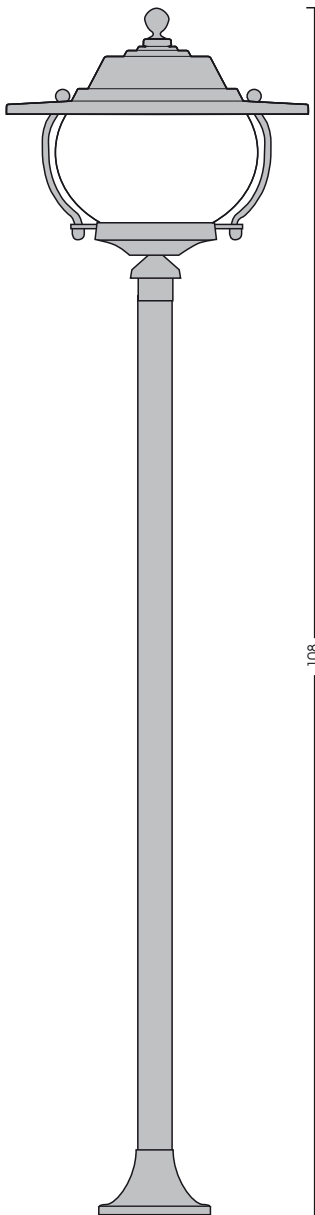

ART. 176.C

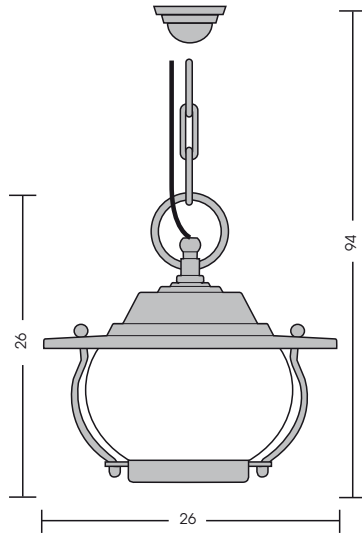

ART. 168.C

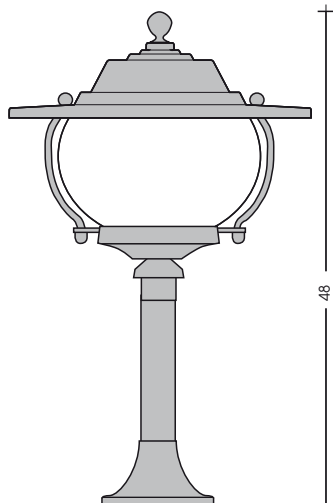

ART. 175.C

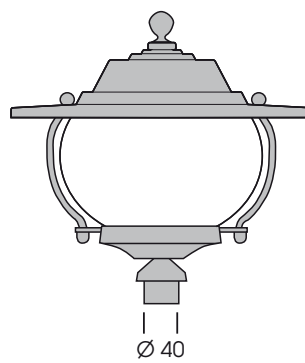

ART. 175B.C

Attacco per palo
Ø 40 mm (interno)

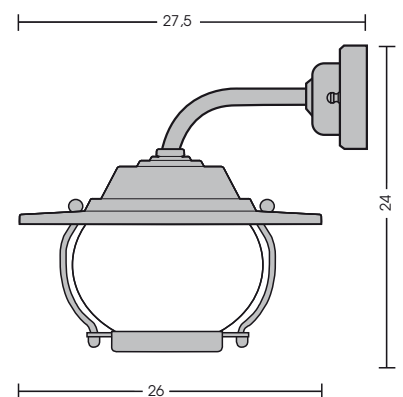

ART. 138.C

IP 44



ART. 167.C

C= ottone cromato satinato

IP 43 E 27 Max Watt 60 15/20 Watt



Ottone Cromato

OTTONE CROMATO PER INTERNI ED ESTERNI

(non teme la salsedine)

LAITON CHROMÉ POUR L'INTÉRIEUR ET L'EXTÉRIEUR
INDOOR AND OUTDOOR CHROMIUM-PLATED BRASS

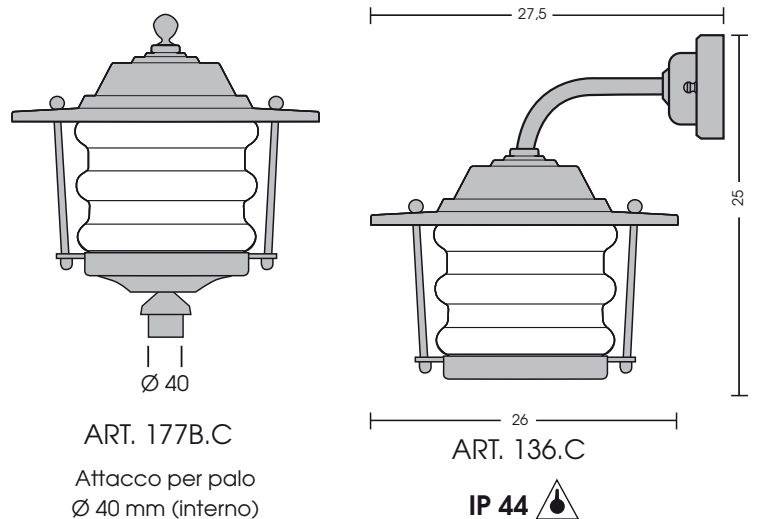
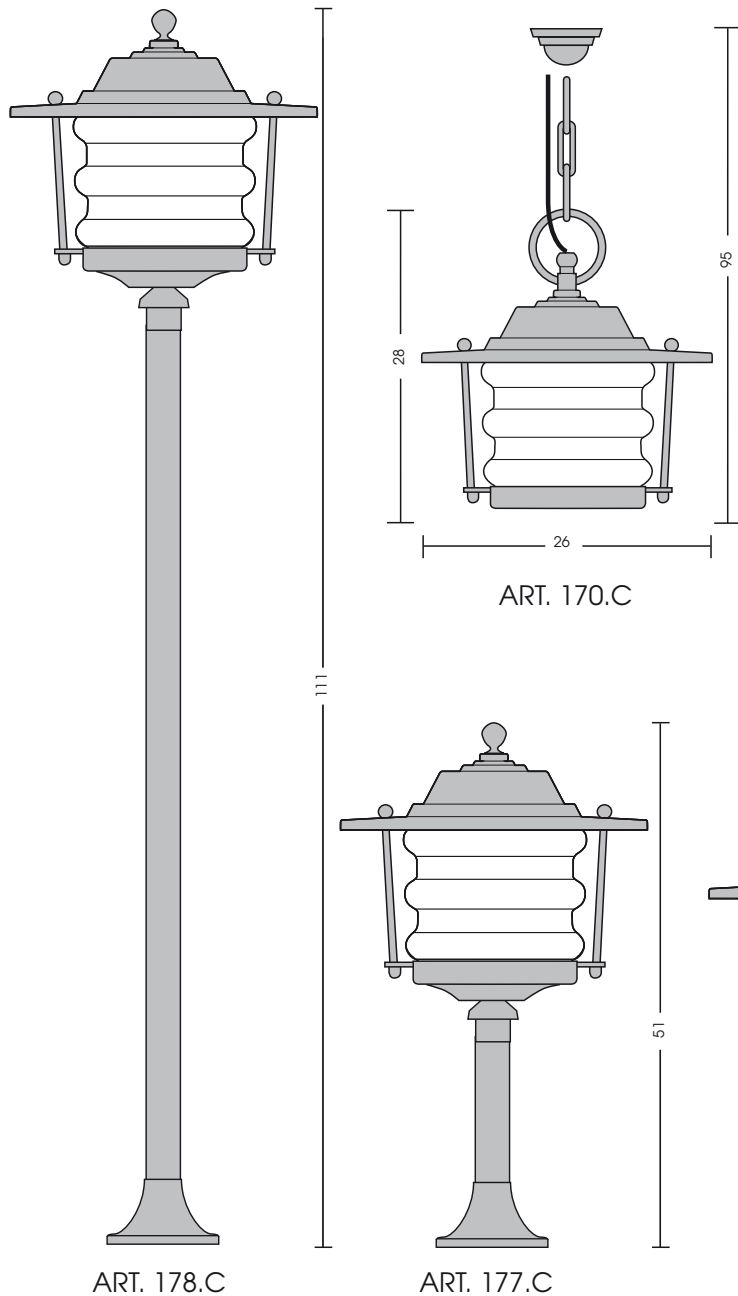
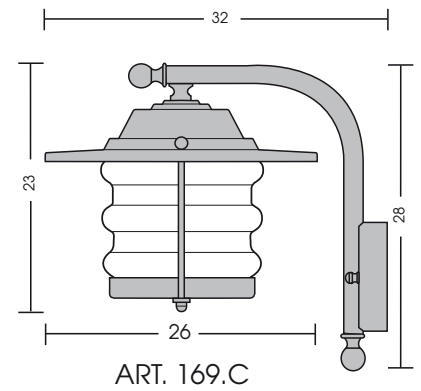

IP 43 E 27 Max Watt 60 15/20 Watt



ART. 177.C

ART. 178.C

Ottone Cromato

OTTONE CROMATO PER INTERNI ED ESTERNI

(non teme la salsedine)

LAITON CHROMÉ POUR L'INTÉRIEUR ET L'EXTÉRIEUR
INDOOR AND OUTDOOR CHROMIUM-PLATED BRASS

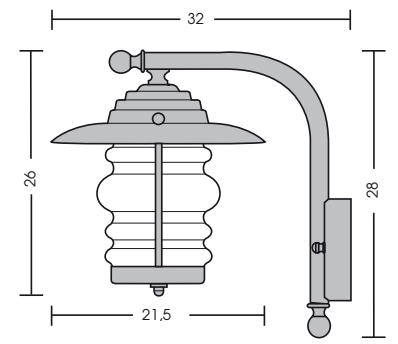

ART. 171.C

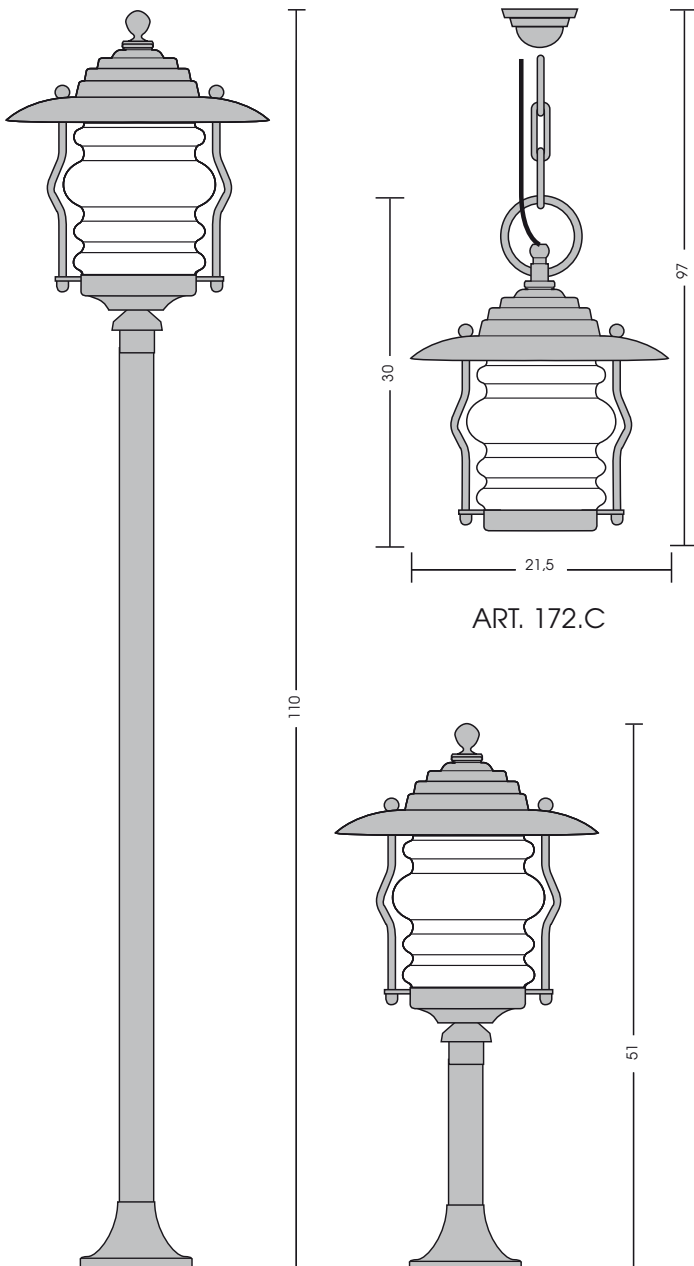

ART. 172.C

ART. 196.C

ART. 195.C



ART. 171.C

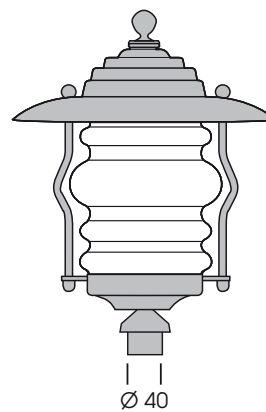

ART. 195B.C

Attacco per palo
Ø 40 mm (interno)

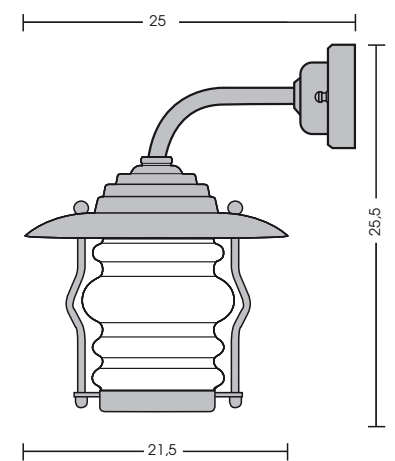

ART. 137.C

IP 44

C= ottone cromato satinato

IP 43 E 27 Max Watt 60 15/20 Watt



Ottone Cromato

OTTONE CROMATO PER INTERNI ED ESTERNI **(non teme la salsedine)**
LAITON CHROMÉ POUR L'INTÉRIEUR ET L'EXTÉRIEUR
INDOOR AND OUTDOOR CHROMIUM-PLATED BRASS

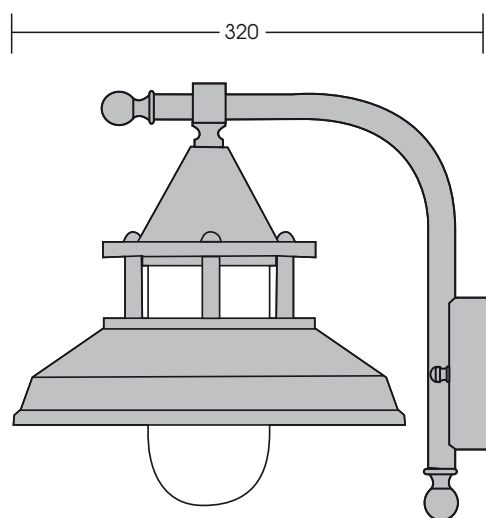

ART. 120.C

IP 44

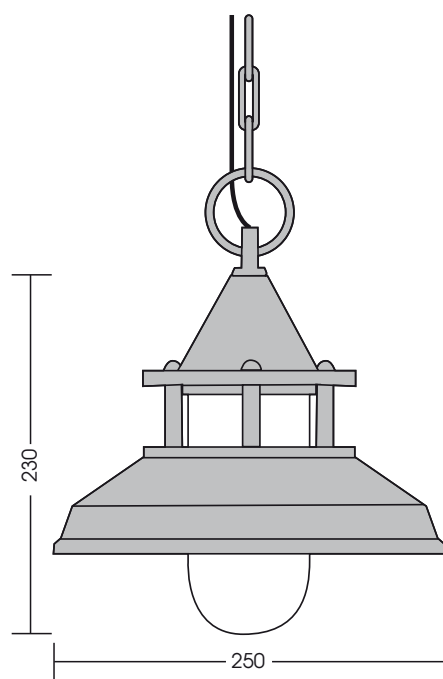

ART. 122.C

IP 43 Max Watt 60

E 27 Max Watt 75 20/23 Watt

C= ottone cromato satinato

Cavo sospensione neoprene nero per esterni



Silver ocean

(OTTONE NICHELATO)

PLAFONIERE PER ESTERNI / LUMINAIRES POUR EXTÉRIEUR / OUTDOOR LIGHTING
DECKENLAMPE FÜR DEN AUßENRAUM

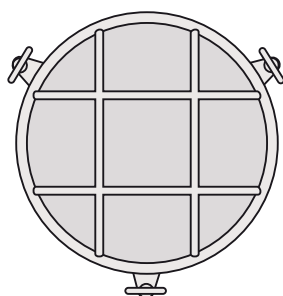

ART. 200.20
Larg. 21

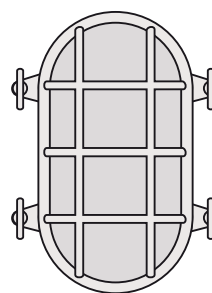

ART. 200.21
Larg. 15 - H. 22,5

CORPO: Ottone - CORPS: Laiton - BODY: Brass - KÖRPER: Messing
COLORE: Argento - COULEUR: Argent - COLOR: Silver - FARBE: Silber
VETRO: Opale o trasparente - VERRE: Blanc ou transparent - GLASS: White or transparent
MILCHGLAS: Oder transparentes Glas

 18 W Genie (200.20 e 200.21) - IP 44   E 27  Max Watt 60

PLAFONIERE PER INTERNI / LUMINAIRES POUR INTÉRIEUR / INDOOR LIGHTING
DECKENLAMPE FÜR DEN INNENRAUM

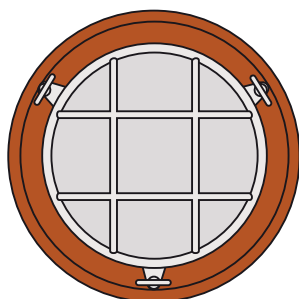

ART. 200.22
Larg. 28

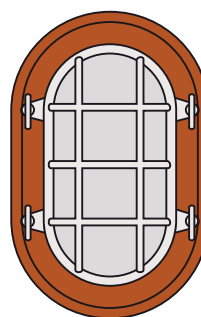

ART. 200.23
Larg. 19 - H. 29,5

CORPO: Ottone e legno - CORPS: Laiton et bois - BODY: Brass and wood - KÖRPER: Messing
COLORE: Argento - COULEUR: Argent - COLOR: Silver - FARBE: Silber
VETRO: Opale o trasparente - VERRE: Blanc ou transparent - GLASS: White or transparent
MILCHGLAS: Oder transparentes Glas

 18 W Genie - IP 20  E 27  Max Watt 60 

