

CHIARIMENTI: L'Antichizzazione è fatta manualmente e la tonalità dell'ottone può avere sfumature diverse da quelle delle foto. L'Antichizzazione fatta a mano non impedisce la naturale ossidazione di questo metallo che, esposto all'esterno, è soggetto all'azione degli eventi naturali. I nostri prodotti non sono autopulenti quindi, se vengono ricoperti da salsedine, devono essere puliti con i normali prodotti per pulizia dei metalli.

Svolta la procedura di pulitura, pian piano nel tempo riprodurranno la patina tipica dell'invecchiamento dell'ottone.

BA= Ottone brunito antichizzato
Laiton vieilli
Brass burnish finishing



AR - BA =

- OTTONE ANTICIZZATO PER INTERNI ED ESTERNI
- INDOOR AND OUTDOOR AGED BRASS
- LAITON POUR INTÉRIEUR ET L'EXTÉRIEUR
- ANTIKISIERTER MESSING FÜR DEN INNENRAUM UND AUßENRAUM

AR= Ottone antichizzato ramato
Aged brass copper-coloured
Laiton vieilli cuivré



.AC.AR.BA= OTTONE ANTICIZZATO / LAITON VIEILLI / AGED BRASS / ANTIKISIERTER MESSING - **non teme la salsedine / no salt corrosion**
Colore vetri / Couleurs verres / Glass colours - **.T** = trasparente - **.O** = opale

News



AC= Ottone antichizzato
non ramato
Aged brass without
copper color



NA= Colore argento antichizzato
Old silver color

.A - Ottone brunito (antichizzato)

Laiton vieilli

Brass burnish finishing



.V - Ottone lucido
con vernice protettiva trasparente

Laiton verni

Polished brass with transparent protection



.D - Ottone bagno oro 24 Kt

Laiton doré 24 carats

Brass 24 Kt gold - dipped



Esempio / Example

Art. 1506.V = ottone lucido - laiton verni - polished brass

Art. 1506.A = ottone brunito antichizzato - laiton vieilli - brass burnish finishing

Colore vetri

Couleurs des opalines - Glass colours - Gläs farbe



.6 - Bianco
- Blanc - White - Weiss



.7 - Ambra
- Paille - Amber - Bernstein



.8 - Verde
- Vert - Green - Grün

Esempio - Example

Art. 1924.A.8= ottone brunito antichizzato con vetro verde
laiton vieilli avec opaline vert
brass burnish finishing with green glass

Sospensioni regolabili

Adjustable suspensions



Art. 1336.T.AR
(con vetro/with glass)

Art. 1336.AR
(senza vetro/without glass)

Estensione max. cm. 128

Estensione min. cm. 83



Art. 1354.T.AR
(con vetro/with glass)

Art. 1354.AR
(senza vetro/without glass)

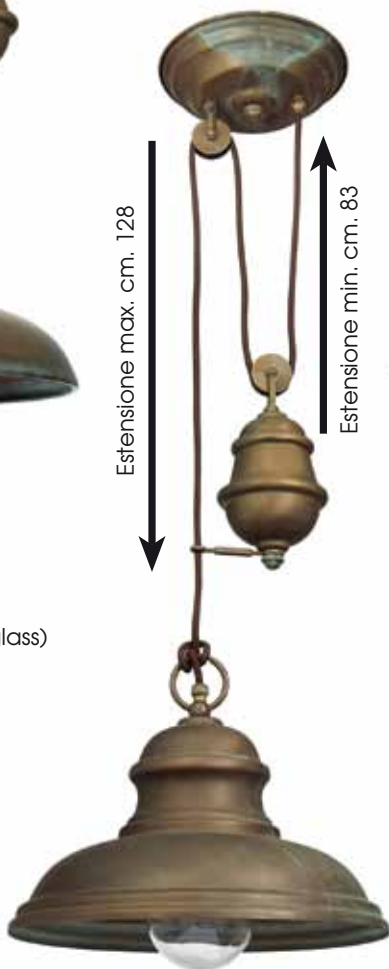

Art. 1596.T.AR
(con vetro/with glass)

Art. 1596.AR
(senza vetro/without glass)



Art. 1346.T.AR
(con vetro/with glass)

Art. 1346.AR
(senza vetro/without glass)

Finitura ottone
Finition laiton
Brass finishes

.A.AR.BA

.AR.BA=
OTTONE ANTICIZZATO
LAITON VIEILLI
AGED BRASS
ANTIKISIERTER MESSING

non teme la salsedine
chiarimenti a Pag. 265
no salt corrosion

Cavo tessuto
Cable tissue
Câble tissu
Kabel stoff

CE IP 20 - E 27

Max Watt 75



20/23 Watt



①
ART. 1962.O.AR
 H. 1030 - Larg. 400

.AR.AC.BA.NA=
 OTTONE ANTICIZZATO PER ESTERNI E INTERNI
 AGED BRASS FOR OUTDOOR AND INDOOR
 LAITON VIEILLI
 ANTIKISIERTER MESSING

non teme la salsedine
no salt corrosion

Finitura ottone per Interni
 Indoor brass finishes
.A.AR.AC.BA.D.NA

Colore vetri
 Couleurs verres
 Glass colours
.T = trasparente
.O = opale



CE IP 44 - E 27
 Max Watt 70



23/25 Watt
 1500 - 1600LM

①



Ø 380



ART. 1781.AR



CE IP 20 - E 27

Max Watt 2 x 23 - Philips 23 W / 827

VETRO: OPALE / GLASS: OPAL



①

②



③



①
ART. 1676.AR
H. 220 - Ø 325

②
ART. 1677.AR
H. min 800 - max 1300
Larg. 1100

③
ART. 1780.AR
H. 780 - Ø 325



.AR.BA=
OTTONE ANTICHIZZATO
LAITON VIEILLI
AGED BRASS
ANTIKISIERTER MESSING
**non teme la salsedine
chiarimenti a Pag. 265
no salt corrosion**
Cavo tessuto
Cable tissu
Câble tissu
Kabel stuff

CE IP 20 - E 27

Max Watt 75



20/23 Watt



ART. 1671.AR



ART. 1670.AR



ART. 1675.BA

A RICHIESTA ANCHE CON VETRO / WITH GLASS TOO / AUSSI AVEC VERRE / AUCH MIT GLÄS **I.T.O.**



② ③ ④ ⑤ con
with
avec 



④
ART. 1678.BA
H. min 820 - max 1250
Larg. 1310

⑤
ART. 1679.BA
H. min 600 - max 960
Larg. 1020

⑥
ART. 1596.T.AR
(con vetro/with glass)
ART. 1596.AR
(senza vetro/without glass)



ART. 1672.AR



ART. 1673.AR



ART. 1674.AR



A RICHIESTA ANCHE CON VETRO / WITH GLASS TOO / AUSSI AVEC VERRE / AUCH MIT GLÄS .T.O



base Ø 100



①

base Ø 90



②



④



③



⑤



①
ART. 1934.AR
H. 200 - Larg. 170 - Ø 160

②
ART. 1930.AR
H. 200 - Larg. 340/90°

③
ART. 1931.A
H. 200 - Larg. 410/45°

④
ART. 1932.NA
H. 190 - Larg. 415

⑤
ART. 1933.A
H. 190 - Larg. 715

.AR.AC.BA.NA=
OTTONE ANTICIZZATO
AGED BRASS
LAITON VIEILLI
ANTIKISIERTER MESSING

non teme la salsedine
no salt corrosion

Finitura ottone per Interni
Indoor brass finishes
.A.AR.AC.BA.NA.V

Colore vetri a pagina 18
Couleurs verres à la page 18
Glass colours page 18

CE IP 20 - E 27

Max Watt 60





①
ART. 1924.A.8
H. 200 - Larg. 144

②
ART. 1920.A.7
H. 255 - Larg. 330/30°

③
ART. 1921.AR.6
H. 230 - Larg. 400/45°

④
ART. 1922.A.7
H. 210 - Larg. 410

⑤
ART. 1923.BA.8
H. 210 - Larg. 670

.AR.AC.BA.NA=
OTTONE ANTICIZZATO
AGED BRASS
LAITON VIEILLI
ANTIKISIERTER MESSING

non teme la salsedine
no salt corrosion

Finitura ottone per Interni
Indoor brass finishes
.A.AR.AC.BA.NA.V

Colore vetri a pagina 18
Couleurs verres à la page 18
Glass colours page 18

CE IP 20 - E 27

⚡ Max Watt 60





①
ART. 1720.T.AR
 H. 730 - Larg. 620 - Kg. 3,70

②
ART. 1721.T.AR
 H. 3080 - Larg. 650 - Kg. 17

③
ART. 1722.T.AR
 H. 3080 - Larg. 1250 - Kg. 20



.AR.BA=
 OTTONE ANTICHIZZATO
 LAITON VIEILLI
 AGED BRASS
 ANTIKISIERTER MESSING

**non teme la salsedine
 no salt corrosion**

Colore vetri
 Couleurs verres
 Glass colours
.T = trasparente
.O = opale

Palo IP 55 Lanterna IP 44
 Pole IP 55 Light IP 44
 Pieu IP 55 Lumiere IP 44

CE IP 44 - E 27

Max Watt 75

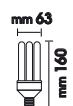

20/23 Watt



PIASTRA

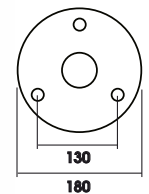
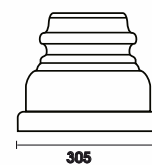

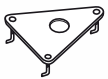

**Piastra
fissaggio
cod. APR8**

④
ART. 1722.T.BA
H. 3080 - Larg. 1250
Kg. 20

⑤
ART. 1723.T.AR
H. 3080 - Larg. 1130
Kg. 24



.AR.BA=
OTTONE ANTICIZZATO
LAITON VIEILLI
AGED BRASS
ANTIKISIERTER MESSING

**non teme la salsedine
no salt corrosion**

Colore vetri
Couleurs verres
Glass colours
.T = trasparente
.O = opale

CE IP 44 - E 27

Max Watt 75



20/23 Watt





①

①
ART. 1697.AR
H. 830 - Ø 300



②

②
ART. 1698.BA
H. min 710 - max 1070
Larg. 1100

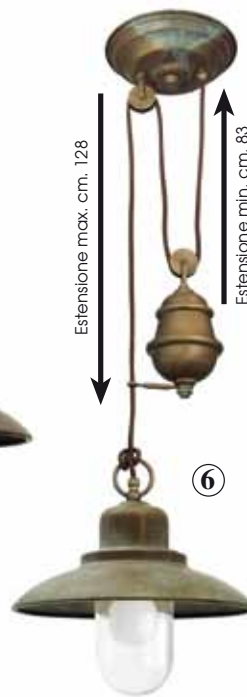

⑥

Estensione max. cm. 128

Estensione min. cm. 83

③
ART. 1696.BA
H. 220 - Ø 300



.AR.BA=
OTTONE ANTICIZZATO
LAITON VIEILLI
AGED BRASS
ANTIKISIERTER MESSING

**non teme la salsedine
no salt corrosion**

Cavo tessuto
Cable tissue
Câble tissu
Kabel stuff

CE IP 20 - E 27
Max Watt 75



20/23 Watt



③

A RICHIESTA ANCHE CON VETRO / WITH GLASS TOO / AUSSI AVEC VERRE / AUCH MIT GLÄS **.T.O.**



④

① ② ④ ⑤ con with avec



⑤

④

ART. 1699.AR
H. min 800 - max 1300 - Larg. 1100

⑤

ART. 1712.BA
H. min 800 - max 1300 - Larg. 1300

⑥

ART. 1354.T.AR
(con vetro/with glass)
ART. 1354.AR
(senza vetro/without glass)



ART. 1690.AR

ART. 1692.AR

ART. 1695.AR

ART. 1694.AR

ART. 1693.AR

A RICHIESTA ANCHE CON VETRO / WITH GLASS TOO / AUSSI AVEC VERRE / AUCH MIT GLÄS **.T.O.**



①
ART. 1628.AR
H. 820 - Ø 300

②
ART. 1629.AR
H. min 600 - max 960
Larg. 1020

③
ART. 1627.BA
H. 200 - Ø 300



.AR.BA=
OTTONE ANTICHIZZATO
LAITON VIEILLI
AGED BRASS
ANTIKISIERTER MESSING

non teme la salsedine
no salt corrosion

Cavo tessuto
Cable tissue
Câble tissu
Kabel stoff

CE IP 20 - E 27

Max Watt 75



20/23 Watt

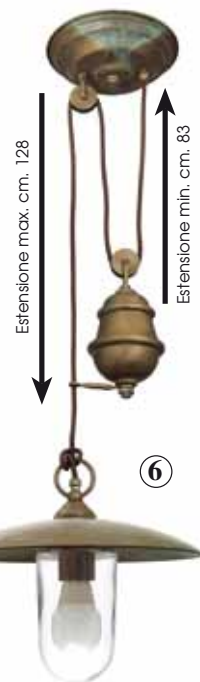

A RICHIESTA ANCHE CON VETRO / WITH GLASS TOO / AUSSI AVEC VERRE / AUCH MIT GLÄS **T.O.**



④

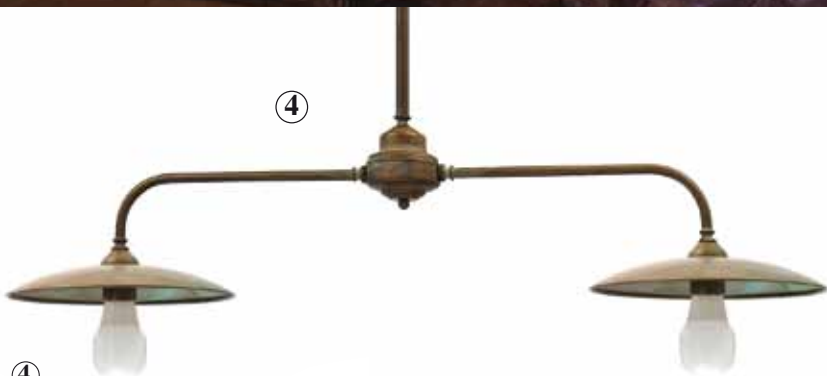

④

ART. 1630.AR

H. min 730 - max 1200 - Larg. 1113

⑤

ART. 1631.AR

H. min 820 - max 1250 - Larg. 1310

⑥

ART. 1346.T.AR

(con vetro/with glass)

ART. 1346.AR

(senza vetro/without glass)

① ② ④ ⑤ con with avec 

⑤



ART. 1620.BA



ART. 1621.AR



ART. 1622.AR



ART. 1623.AR



ART. 1624.AR



ART. 1626.AR

A RICHIESTA ANCHE CON VETRO / WITH GLASS TOO / AUSSI AVEC VERRE / AUCH MIT GLÄS **.T.O**



④

④
ART. 1333.T.AR
 H. 320 - Ø 320 - IP 43



⑤

⑤
ART. 1334.T.AR
 H. 630 - Ø 320 - IP 43



⑥

ART. 1332.T.AR trasparente
ART. 1332.TO.AR opale



⑦

ART. 1332.TT.AR trasparente
ART. 1332.TO.AR opale

⑦
ART. 1332.TT.AR
 H. 900 - Ø 320 - IP 43



Vetri disponibili in due forme diverse
 Glasses available in two different shapes



①

①
ART. 1656.AR
H. 330 - Ø 320



②

②
ART. 1657.AR
H. min 800 - max 1300
Larg. 1100



③

③
ART. 1658.AR
H. 830 - Ø 320

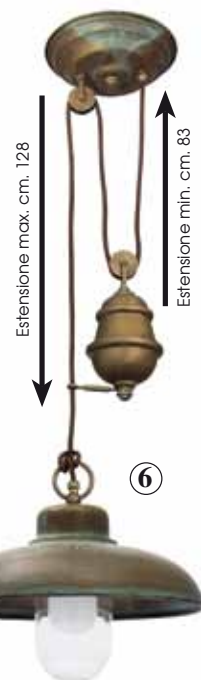

⑥

Estensione max. cm. 128

Estensione min. cm. 83



.AR.BA=
OTTONE ANTICIZZATO
LAITON VIEILLI
AGED BRASS
ANTIKISIERTER MESSING

non teme la salsedine
no salt corrosion

Cavo tessuto
Cable tissu
Câble tissu
Kabel stoff

CE IP 20 - E 27

Light bulb icon Max Watt 75



20/23 Watt



ART. 1650.AR



ART. 1651.BA

A RICHIESTA ANCHE CON VETRO / WITH GLASS TOO / AUSSI AVEC VERRE / AUCH MIT GLÄS **.T.O**



② ③ ④ ⑤ con with with avec 

- ④
ART. 1660.BA
H. min 600 - max 960
Larg. 1020
- ⑤
ART. 1659.BA
H. min 820 - max 1250
Larg. 1310
- ⑥
ART. 1336.T.AR
(con vetro/with glass)
- ART. 1336.AR**
(senza vetro/without glass)



ART. 1653.AR



ART. 1652.AR



ART. 1654.AR



ART. 1655.AR

A RICHIESTA ANCHE CON VETRO / WITH GLASS TOO / AUSSI AVEC VERRE / AUCH MIT GLÄS **.I.O**



Spotisland

①
ART. 1520.E27.AR
H. 150 - Larg. 90

②
ART. 1411.GU10.AR
H. 184 - Larg. 90

③
ART. 1412.E27.BA
H. 165 - Larg. 290

④
ART. 1421.E27.BA
H. 165 - Larg. 645



.AR.BA=
OTTONE ANTICIZZATO
LAITON VIEILLI
AGED BRASS
ANTIKISIERTER MESSING

**non teme la salsedine
no salt corrosion**

Finitura ottone
Finition laiton
Brass finishes
.A.AR.BA.V

CE IP 20 - E 27

💡 Max Watt 1x60

LED GU10
alogeno GU10

💡 Max Watt 1x50



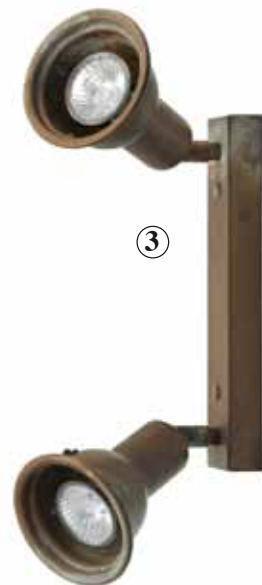

Spotisland

- ①
ART. 1521.E27.AR
H. 175 - Larg. 95
- ②
ART. 1547.GU10.A
H. 213 - Larg. 95
- ③
ART. 1548.GU10.AR
H. 195 - Larg. 295
- ④
ART. 1549.GU10.BA
H. 187 - Larg. 645

.AR.BA=
OTTONE ANTICIZZATO
LAITON VIEILLI
AGED BRASS
ANTIKISIERTER MESSING

**non teme la salsedine
no salt corrosion**

Finitura ottone
Finition laiton
Brass finishes
.A.AR.BA.V

CE IP 20 - E 27
Max Watt 1x60

LED GU10
alogeno GU10
Max Watt 1x50

base Ø 100



base Ø 85



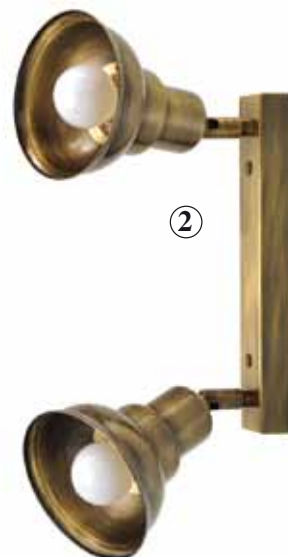

Spotisland

①
ART. 1072.AR
H. 205 - Larg. 115

②
ART. 1556.A
H. 200 - Larg. 310

③
ART. 1558.BA
H. 200 - Larg. 645



.AR.BA=
OTTONE ANTICIZZATO
LAITON VIEILLI
AGED BRASS
ANTIKISIERTER MESSING

**non teme la salsedine
no salt corrosion**

Finitura ottone
Finition laiton
Brass finishes
.A.AR.BA.V

CE IP 20 - E 27

⚡ Max Watt 1x60

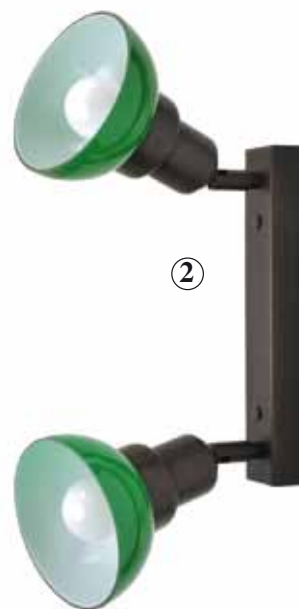

Spotisland

①
ART. 1069.AR.7
H. 200 - Larg. 115

②
ART. 1542.BA.8
H. 205 - Larg. 320

③
ART. 1543.A.6
H. 205 - Larg. 670



.AR.BA=
OTTONE ANTICIZZATO
LAITON VIEILLI
AGED BRASS
ANTIKISIERTER MESSING

**non teme la salsedine
no salt corrosion**

COLORI VETRI
COULEURS DES OPALINES
GLASS COLOURS
.3.4.6.7.8.9

Finitura ottone
Finition laiton
Brass finishes

.A.AR.BA.V

CE IP 20 - E 27

⚡ Max Watt 1x60



Spotisland

①
ART. 1523.V
H. 210 - Ø 116

②
ART. 1535.BA
H. 225 - Larg. 315

③
ART. 1536.AR
H. 225 - Larg. 667



.AR.BA=
OTTONE ANTICIZZATO
LAITON VIEILLI
AGED BRASS
ANTIKISIERTER MESSING

non teme la salsedine
no salt corrosion

Finitura ottone
Finition laiton
Brass finishes

.A.AR.BA.V

CE IP 20 - E 27

⚡ Max Watt 1x60



Spotisland

④
ART. 1524.V.8
H. 210 - Larg. 120

⑤
ART. 1532.AR.6
H. 230 - Larg. 310

⑥
ART. 1533.A.7
H. 230 - Larg. 660



.AR.BA=
OTTONE ANTICIZZATO
LAITON VIEILLI
AGED BRASS
ANTIKISIERTER MESSING

**non teme la salsedine
no salt corrosion**

COLORI VETRI
COULEURS DES OPALINES
GLASS COLOURS
.3.4.6.7.8.9

Finitura ottone
Finition laiton
Brass finishes

.A.AR.BA.V

CE IP 20 - E 27

💡 Max Watt 1x60



Spotisland

①
ART. 1460.AR
H. 150 - Ø 90

②
ART. 1461.BA
H. 180 - Ø 90

③
ART. 1462.A
H. 150 - Larg. 260

④
ART. 1463.AR
H. 150 - Larg. 610



.AR.BA=
OTTONE ANTICHIZZATO
LAITON VIEILLI
AGED BRASS
ANTIKISIERTER MESSING

**non teme la salsedine
no salt corrosion**

Finitura ottone
Finition laiton
Brass finishes
.A.AR.BA.V

CE IP 20 - E 27

💡 Max Watt 1x60

LED GU10
alogeno GU10
💡 Max Watt 1x50





**BARRE DI SOSTEGNO
OTTONE - BRASS - LAITON - MESSING**

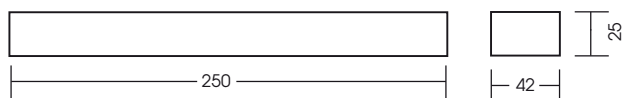
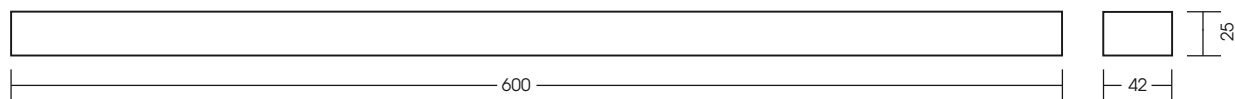

Casale

CERAMICA

.A.AR.BA = OTTONE PER INTERNI / LAITON POUR INTÉRIEUR
INDOOR BRASS / GLÄNZENDER MESSING FÜR DEN INNENRAUM

.AR.BA = OTTONE PER ESTERNI
LAITON POUR L'EXTÉRIEUR / OUTDOOR AGED BRASS
MESSING FÜR DEN AUBENRAUM

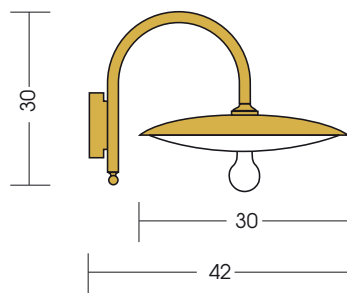

ART. 805P

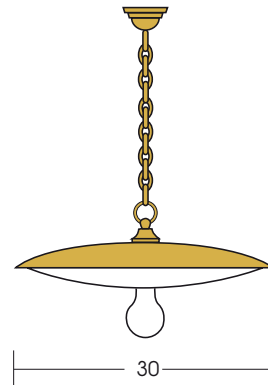

ART. 806P

IP 23 E 27 Max Watt 100

Finitura ottone
Finition laiton
Brass finishes

.A.AR.BA

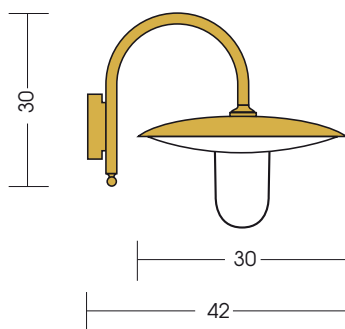

ART. 993P.O
ART. 993P.T

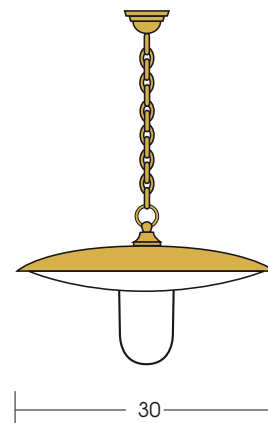

ART. 994P.O
ART. 994P.T

ART. 993 IP 44 E 27 Max Watt 75

ART. 994 IP 43 E 27 Max Watt 60

Finitura ottone
Finition laiton
Brass finishes

.A.AR.BA

O= opale/opal glass. T= trasparente/trasparent glass. P= ceramica/ceramic.

AR/BA= (non teme la salsedine)

Cavo sospensione neoprene nero per esterni



ART. 994P.A.O

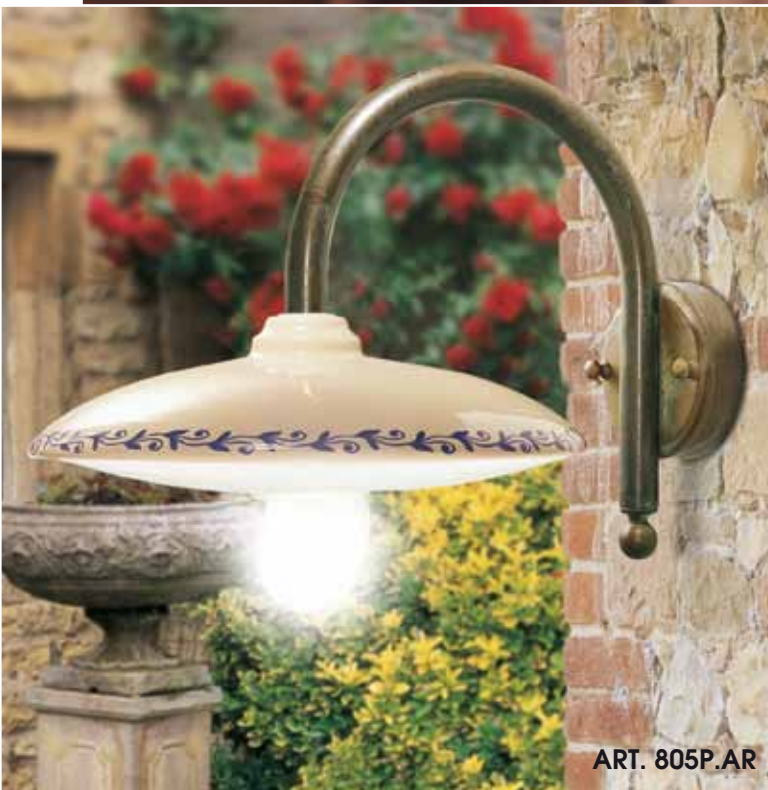

ART. 805P.AR

Casale

Ottone Antichizzato

.A = OTTONE PER INTERNI / LAITON POUR INTÉRIEUR
INDOOR BRASS / GLÄNZENDER MESSING FÜR DEN INNENRAUM

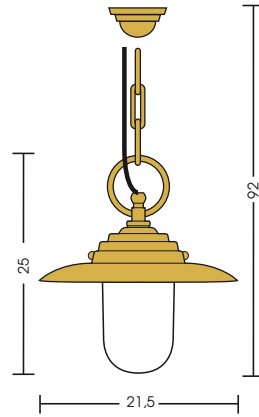

ART. 162.O.A
ART. 162.T.A

↑
ART. 161.O.A
ART. 161.T.A



←
ART. 163.O.A
ART. 163.T.A

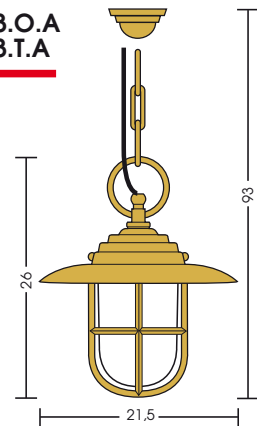

ART. 164.O.A
ART. 164.T.A

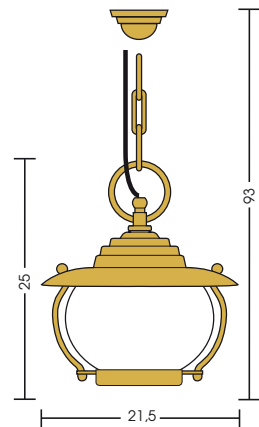
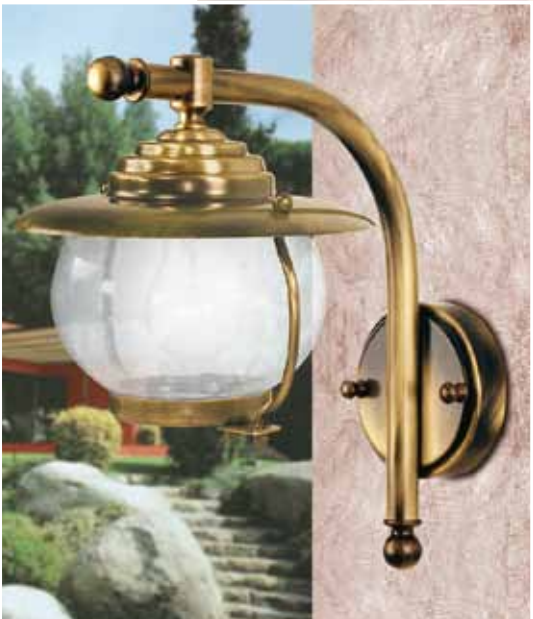

ART. 166.A

SOLO CON VETRO TRASPARENTE
TRANSPARENT GLASS ONLY

↑
ART. 165.A O= opale. T= trasparente.

.A= vernice con antichizzazione

Art. 161 - 162 - 163 - 164 - 165 vetro trasparente

Art. 161 - 163 IP 44 Art. 162 - 164 - 165 - 166 IP 43 E 27 Max Watt 60 15/20 Watt

Ottone Antichizzato

.A = OTTONE PER INTERNI / LAITON POUR INTÉRIEUR
INDOOR BRASS / GLÄNZENDER MESSING FÜR DEN INNENRAUM



↑
ART. 167.A

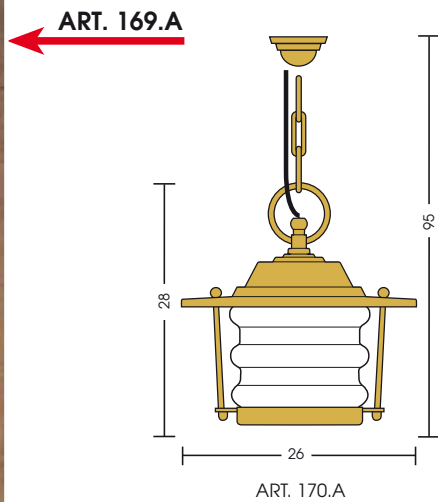
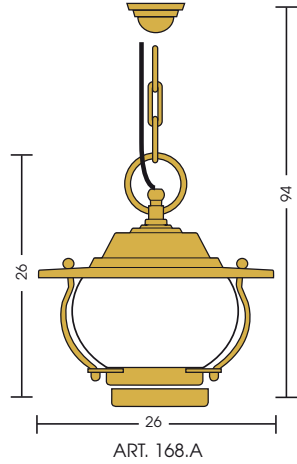

↑
ART. 171.A

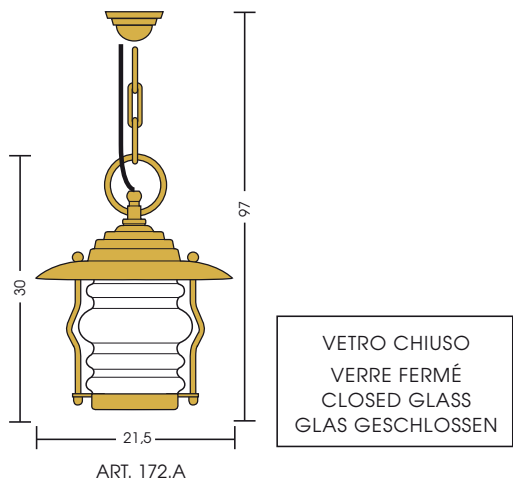

.A= vernice con antichizzazione

IP 43 E 27 Max Watt 60 15/20 Watt

Cavo sospensione neoprene nero per esterni

Serie Goletta



ART. 1240.AR.O
H. 450 - Larg. 300 - Prof. 330
Paterre Ø 105



ART. 1242.V.O
H. 350 - Larg. Ø 300



ART. 1243.AR.O
H. 450 - Larg. 390

IP 20  E 27

 Max Watt 100  20/23 Watt

Finitura ottone
Finition laiton
Brass finishes

.A.AR.V

Colore vetri
Couleurs des opalines
Glass colours

.O = opale
.T = trasparente

ART. 1244.A.O
H. 550 - Larg. 860 - Ø 300



ART. 1246.AR.O
H. 550 - Larg. 720 - Ø 300

Serie Goletta

IP 20  E 27  Max Watt 100  20/23 Watt

Finitura ottone
Finition laiton
Brass finishes

.A.AR.V

Colore vetri
Couleurs des opalines
Glass colours

.O = opale
.T = trasparente

Serie Baia



ART. 1201.AR.7
H. 270 - Larg. 200 - Prof. 220
Paterre Ø 90





ART. 1200.V.6
H. 470 - Larg. 250
Base Ø 175



ART. 1200.V.8
H. 470 - Larg. 250
Base Ø 175

IP 20  E 27

 Max Watt 60

 15/20 Watt

Finitura ottone
Finition laiton
Brass finishes

.A.AR.V

Colore vetri
Couleurs des opalines
Glass colours **.3.4.6.7.8.9**

Serie Baia



ART. 1207.AR.3
H. 325 - Larg. 260 - Prof. 285
Paterre Ø 105



ART. 1207.A.7
H. 325 - Larg. 260
Prof. 285
Paterre Ø 105



ART. 1207.A.3
H. 325 - Larg. 260 - Prof. 285 - Paterre Ø 105



ART. 1207.A.4
H. 325 - Larg. 260
Prof. 285
Paterre Ø 105

IP 20



E 27



Max Watt 60



15/20 Watt

Finitura ottone
Finition laiton
Brass finishes

.A.AR.V

Colore vetri
Couleurs des opalines
Glass colours

.3.4.6.7.8.9

Serie Baia



ART. 1213.V.8
H. 380 - Larg. 315 - Prof. 350
Paterre Ø 105
Max Watt 60  15/20 Watt



ART. 1214.A.8
H. 320 - Larg. 315



ART. 1217.AR.6
H. 365 - Larg. 370



IP 20  E 27

 Max Watt 100  20/23 Watt

Finitura ottone
Finition laiton
Brass finishes

.A.AR.V

Colore vetri
Couleurs des opalines
Glass colours **.3.4.6.7.8.9**

Serie Baia

ART. 1212.A.3
H. 430 - Larg. 645
Ø 260

ART. 1215.AR.7
H. 470 - Larg. 1100
Ø 315

IP 20  E 27

 Max Watt 100  20/23 Watt

Finitura ottone
Finition laiton
Brass finishes **.A.AR.V.BA**

Colore vetri
Couleurs des opalines
Glass colours **.3.4.6.7.8.9**



ART. 1208 - H. 230 - Larg. 260

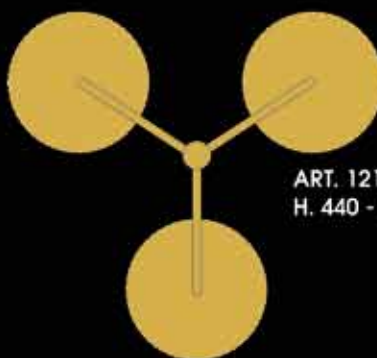

ART. 1211
H. 440 - Larg. 730 - Ø 260

ART. 1209.AR.8
H. 420 - Larg. 1040 - Ø 260

Max Watt 100
20/23 Watt



Serie Baia

ART. 1205.AR.6
H. 370 - Larg. 515
Ø 205

IP 20  E 27  Max Watt 75  15/20 Watt

Finitura ottone
Finition laiton
Brass finishes

.A.AR.V.BA

Colore vetri
Couleurs des opalines: **.3.4.6.7.8.9**
Glass colours

Serie Baia

ART. 1216.A.7
H. 470 - Larg. 780
Ø 315

Max Watt 100
20/23 Watt



ART. 1210.AR.6
H. 420 - Larg. 735



Ø 205

IP 20 E 27

Max Watt 60

15/20 Watt

Finitura ottone
Finition laiton
Brass finishes

.A.AR.V

Colore vetri
Couleurs des opalines
Glass colours

.3.4.6.7.8.9

Ø 260

Ø 205

Ø 260

ART. 1206
H. 420 - Larg. 625

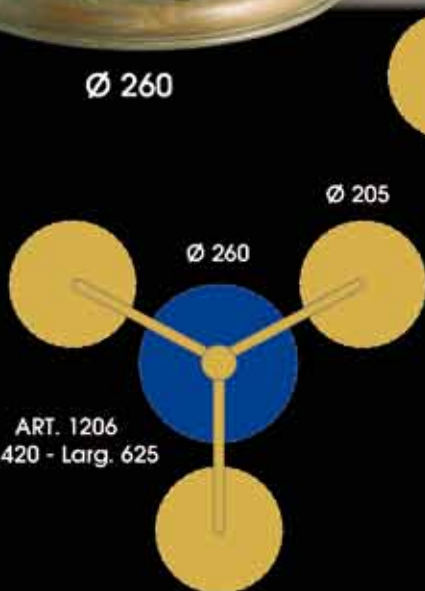

ART. 1204
H. 420 - Larg. 625
Ø 205

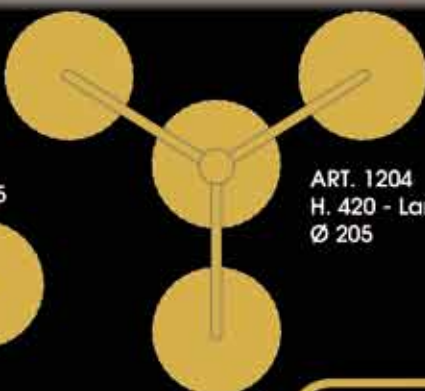

ART. 1202
H. 180 - Ø 205



ART. 1203 - H. 390 - Larg. 760 - Ø 205



Serie Overlander



ART. 1270.V
H. 470 - Larg. 250
Base Ø 105



ART. 1272.A
H. 240 - Larg. 205



ART. 1271.AR
H. 270 - Larg. 200 - Prof. 220
Paterre Ø 90

IP 20  E 27

 Max Watt 60  15/20 Watt

Finitura ottone
Finition laiton
Brass finishes

.A.AR.V



ART. 1277.A
H. 325 - Larg. 260
Prof. 285
Paterre Ø 105

ART. 1283.V
H. 380 - Larg. 315
Prof. 350
Paterre Ø 105

ART. 1277.AR
H. 325 - Larg. 260
Prof. 285
Paterre Ø 105

Serie Overlander

IP 20  E 27
 Max Watt 60  15/20 Watt

Finitura ottone
Finition laiton
Brass finishes

.A.AR.V

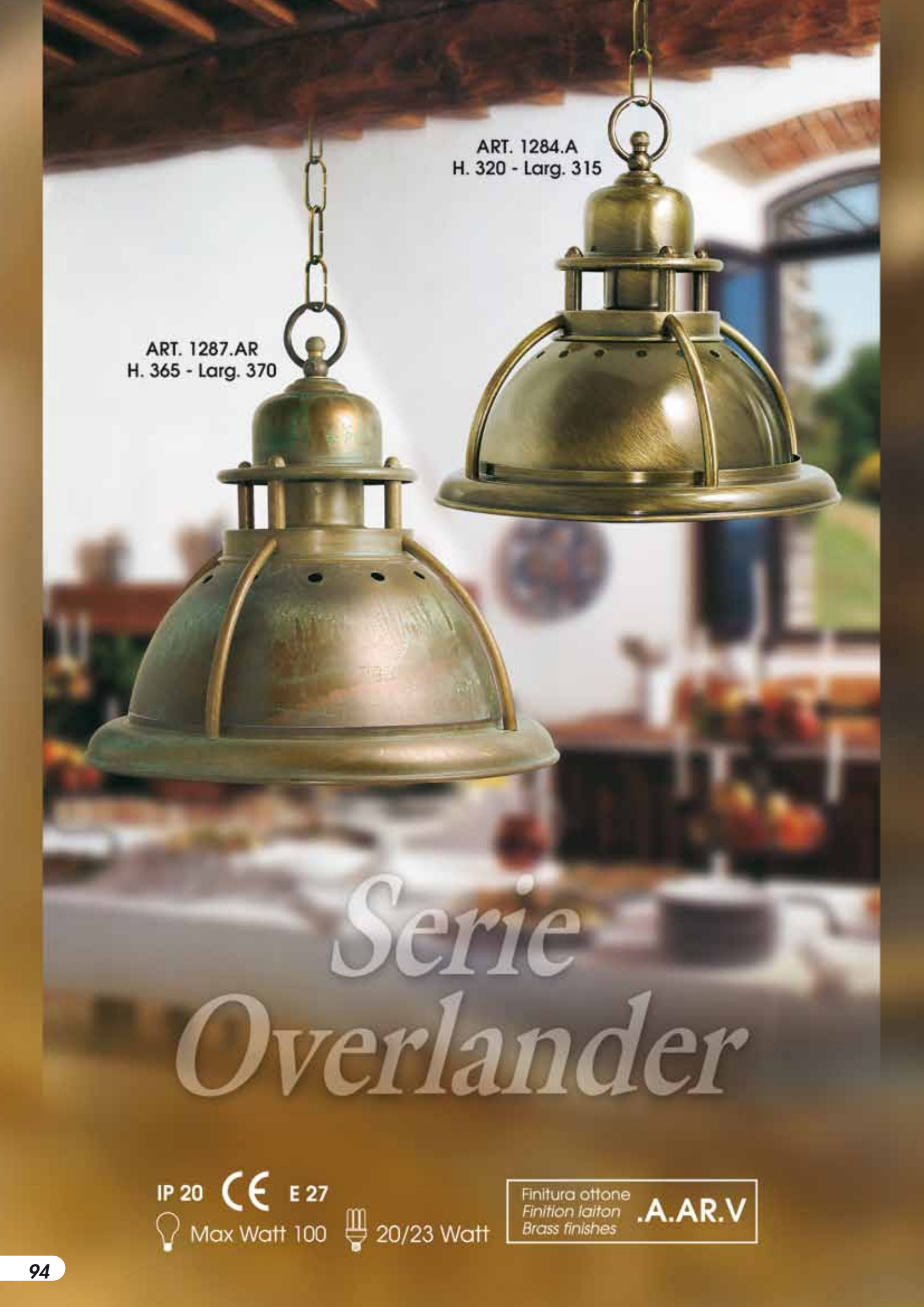

The image shows two brass pendant lamps hanging from a wooden ceiling in a restaurant. The lamp on the left is larger and has a more rounded, dome-like shape with a wide base. The lamp on the right is smaller and has a more compact, rounded shape with a narrower base. Both lamps have a brass finish and a chain suspension. The background is a blurred restaurant interior with tables and chairs.

ART. 1284.A
H. 320 - Larg. 315

ART. 1287.AR
H. 365 - Larg. 370

Serie Overlander

IP 20  E 27

 Max Watt 100  20/23 Watt

Finitura ottone
Finition laiton
Brass finishes

.A.AR.V

ART. 1285.AR
H. 470 - Larg. 1100 - Ø 315





ART. 1282.A
H. 430 - Larg. 645
Ø 260



Serie Overlander

IP 20  E 27

 Max Watt 100  20/23 Watt

Finitura ottone
Finition laiton
Brass finishes

.A.AR.V.BA

Serie Faro



ART. 1251.AR
H. 273 - Larg. 200
Prof. 220
Paterre Ø 90



ART. 1258.AR
H. 400 - Larg. 260 - Prof. 285 - Paterre Ø 105



ART. 1250.V
H. 470 - Larg. 250
Base Ø 175

IP 20  E 27

 Max Watt 60  15/20 Watt

Finitura ottone
Finition laiton
Brass finishes

.A.AR.V

Colore vetri
Couleurs des opalines
Glass colours

opale

Serie Faro

ART. 1258.A
H. 400 - Larg. 260
Prof. 285
Paterre Ø 105



ART. 1264.V
H. 388 - Larg. 315 - Prof. 350
Paterre Ø 105

ART. 1265.A
H. 420 - Larg. 315



IP 20  E 27

 Max Watt 60  15/20 Watt

Finitura ottone
Finition laiton
Brass finishes

.A.AR.V

Colore vetri
Couleurs des opalines
Glass colours

opale

ART. 1260.AR
H. 428 - Larg. 1040
Ø 260

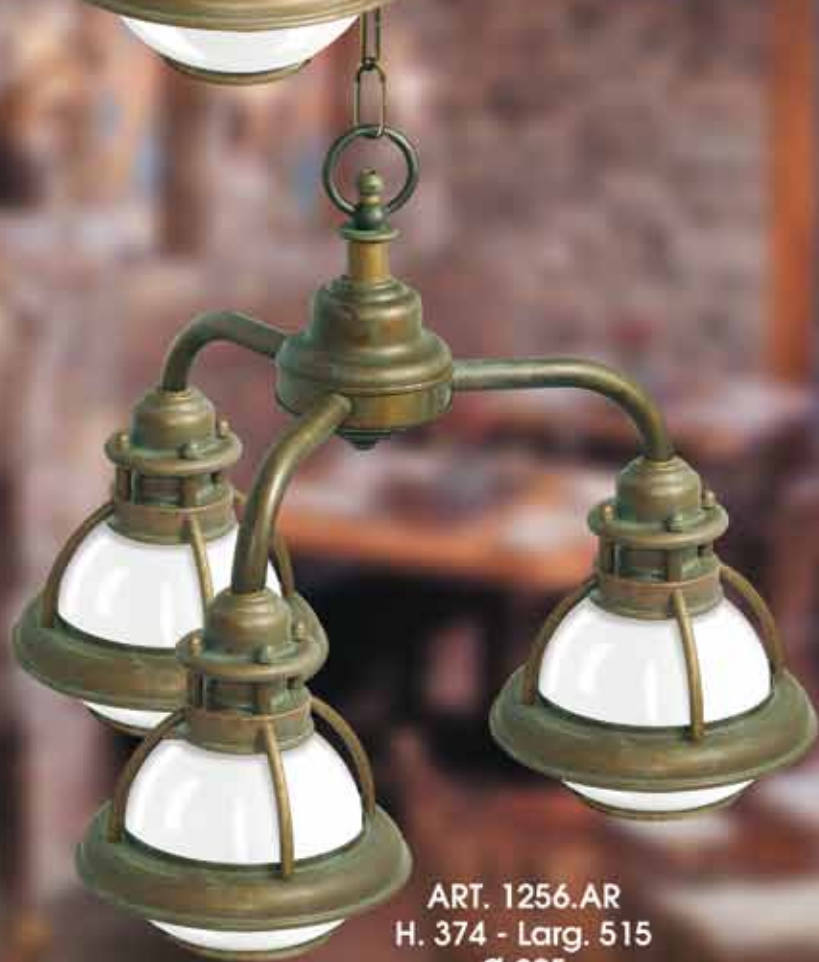

ART. 1256.AR
H. 374 - Larg. 515
Ø 205

Serie Faro

IP 20  E 27  Max Watt 75  15/20 Watt

Finitura ottone
Finition laiton
Brass finishes

.A.AR.V.BA

Colore vetri
Couleurs des opalines
Glass colours

opale

Serie Faro

ART. 1261.AR
H. 424 - Larg. 735



IP 20  E 27  Max Watt 75  15/20 Watt

Finitura ottone
Finition laiton
Brass finishes

.A.AR.V.BA

Colore vetri
Couleurs des opalines
Glass colours

opale

ART. 1252
H. 244 - Larg. 205
Ø 205



Max Watt 60

ART. 1259
H. 300 - Larg. 260
Ø 260



Max Watt 100

ART. 1254
H. 390 - Larg. 760

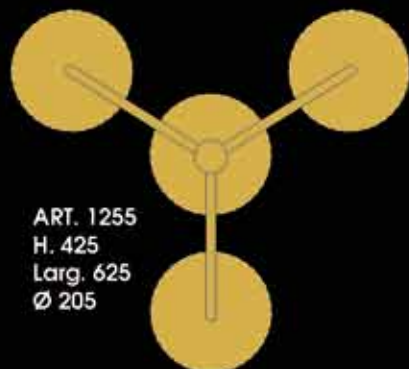

ART. 1255
H. 425
Larg. 625
Ø 205

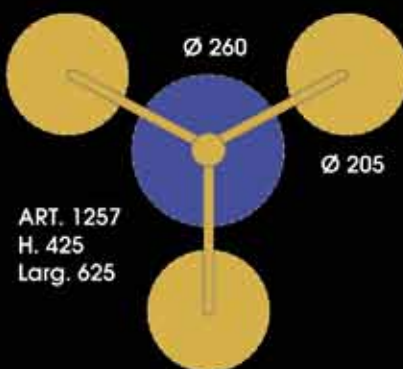

ART. 1257
H. 425
Larg. 625

Ø 260

Ø 205

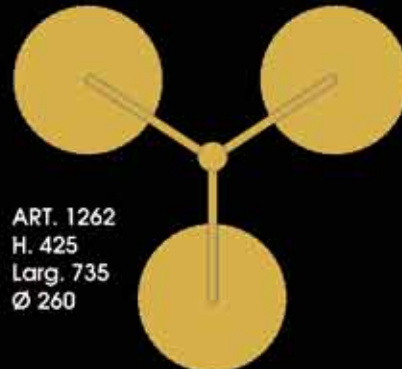

ART. 1262
H. 425
Larg. 735
Ø 260



ART. 1221.AR
H. 270 - Larg. 160
Prof. 200
Paterre Ø 90

ART. 1220.V
H. 220 - Larg. 136
Prof. 165
Paterre Ø 90

Serie Lago

IP 20  E 27

 Max Watt 60  15/20 Watt

Finitura ottone
Finition laiton
Brass finishes

.A.AR.V

Serie Lago



ART. 1222.A
H. 290 - Larg. 200 - Prof. 220 - Paterre Ø 105

IP 20  E 27

 Max Watt 60  15/20 Watt

Finitura ottone
Finition laiton
Brass finishes

.A.AR.V



ART. 1223.AR
H. 470 - Larg. 250
Base Ø 175

ART. 1224
H. 220 - Larg. 200



ART. 1225
H. 380 - Larg. 750



ART. 1228
H. 440 - Larg. 580
Ø 250

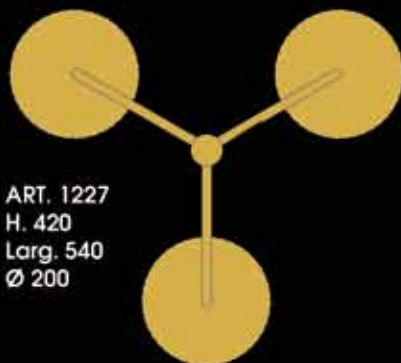

ART. 1227
H. 420
Larg. 540
Ø 200

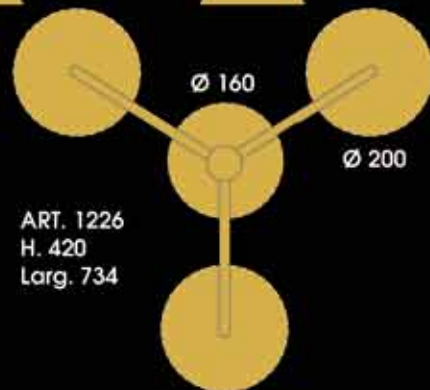

ART. 1226
H. 420
Larg. 734



ART. 1230.V.8
H. 240 - Larg. 140
Prof. 160
Paterre Ø 90



ART. 1230.V.6
H. 240
Larg. 140
Prof. 160
Paterre Ø 90

Serie Tender

IP 20  E 27  Max Watt 60  15/20 Watt

Finitura ottone
Finition laiton
Brass finishes

.A.AR.V

Colore vetri
Couleurs des opalines: **.3.4.6.7.8.9**
Glass colours



ART. 1231.AR.3
H. 295 - Larg. 200
Prof. 200
Paterre Ø 90



ART. 1231.AR.4
H. 295 - Larg. 200 - Prof. 200
Paterre Ø 90

Serie Tender

IP 20  E 27  Max Watt 60  15/20 Watt

Finitura ottone
Finition laiton
Brass finishes

.A.AR.V

Colore vetri
Couleurs des opalines: **.3.4.6.7.8.9**
Glass colours

Serie Tender



ART. 1233.AR.3
H. 470 - Larg. 260
Base Ø 175
Ø vetro 200



ART. 1233.AR.4
H. 470 - Larg. 260
Base Ø 175
Ø vetro 200

IP 20  E 27  Max Watt 60  15/20 Watt

Finitura ottone
Finition laiton
Brass finishes

.A.AR.V

Colore vetri
Couleurs des opalines: **.3.4.6.7.8.9**
Glass colours

Serie Tender



ART. 1232.A.4
H. 330 - Larg. 250
Prof. 280
Paterre Ø 100



ART. 1247.AR.3
H. 430 - Larg. 590 - Ø 250

IP 20  E 27

 Max Watt 60  15/20 Watt

Finitura ottone
Finition laiton
Brass finishes

.A.AR.V

Colore vetri

Couleurs des opalines .3.4.6.7.8.9

Glass colours



ART. 1239
H. 280
Ø vetro 250



ART. 1234
H. 220 - Ø vetro 200



ART. 1235
H. 440 - Larg. 1050 - Ø 250

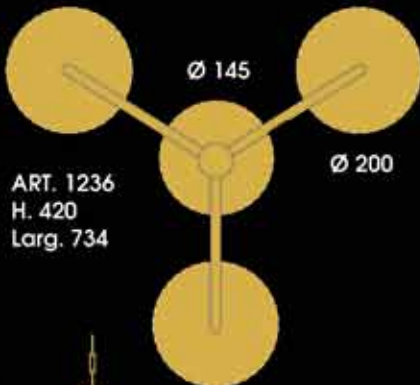

ART. 1236
H. 420
Larg. 734

Ø 145

Ø 200

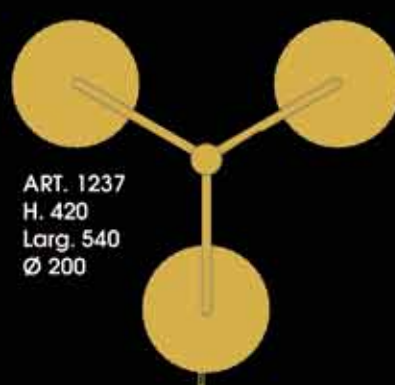

ART. 1237
H. 420
Larg. 540
Ø 200



ART. 1238
H. 440
Larg. 580
Ø 200



ART. 1241
H. 440 - Larg. 800 - Ø 250

Serie Grenadine



ART. 1290.V
H. 245 - Larg. 150
Prof. 160 - Paterre Ø 90



ART. 1291.AR
H. 295 - Larg. 200 - Prof. 200
Paterre Ø 90





ART. 1292.A
H. 330 - Larg. 250 - Prof. 280 - Paterre Ø 100

IP 20  E 27

 Max Watt 60  15/20 Watt

Finitura ottone
Finition laiton
Brass finishes

.A.AR.V

Max Watt 60  15/20 Watt 

Serie Grenadine



ART. 1293.AR
H. 470 - Larg. 260
Base Ø 175
Ø vetro 200



ART. 1301.A
H. 440 - Larg. 590 - Ø 250

Finitura ottone
Finition laiton
Brass finishes

.A.AR.V

IP 20  E 27  Max Watt 100  20/23 Watt



ART. 1294
H. 280 - Ø 200



ART. 1299
H. 230 - Ø 250



ART. 1295
H. 440 - Larg. 1050 - Ø 250

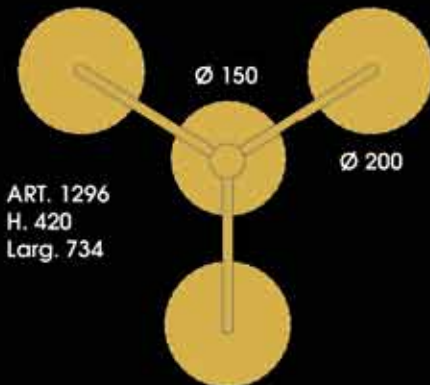

ART. 1296
H. 420
Larg. 734

Ø 150
Ø 200



ART. 1298
H. 440
Larg. 580
Ø 200



ART. 1300
H. 440 - Larg. 800 - Ø 250

Serie Vanua

ART. 1005.AR
H. 400 - Larg. 420

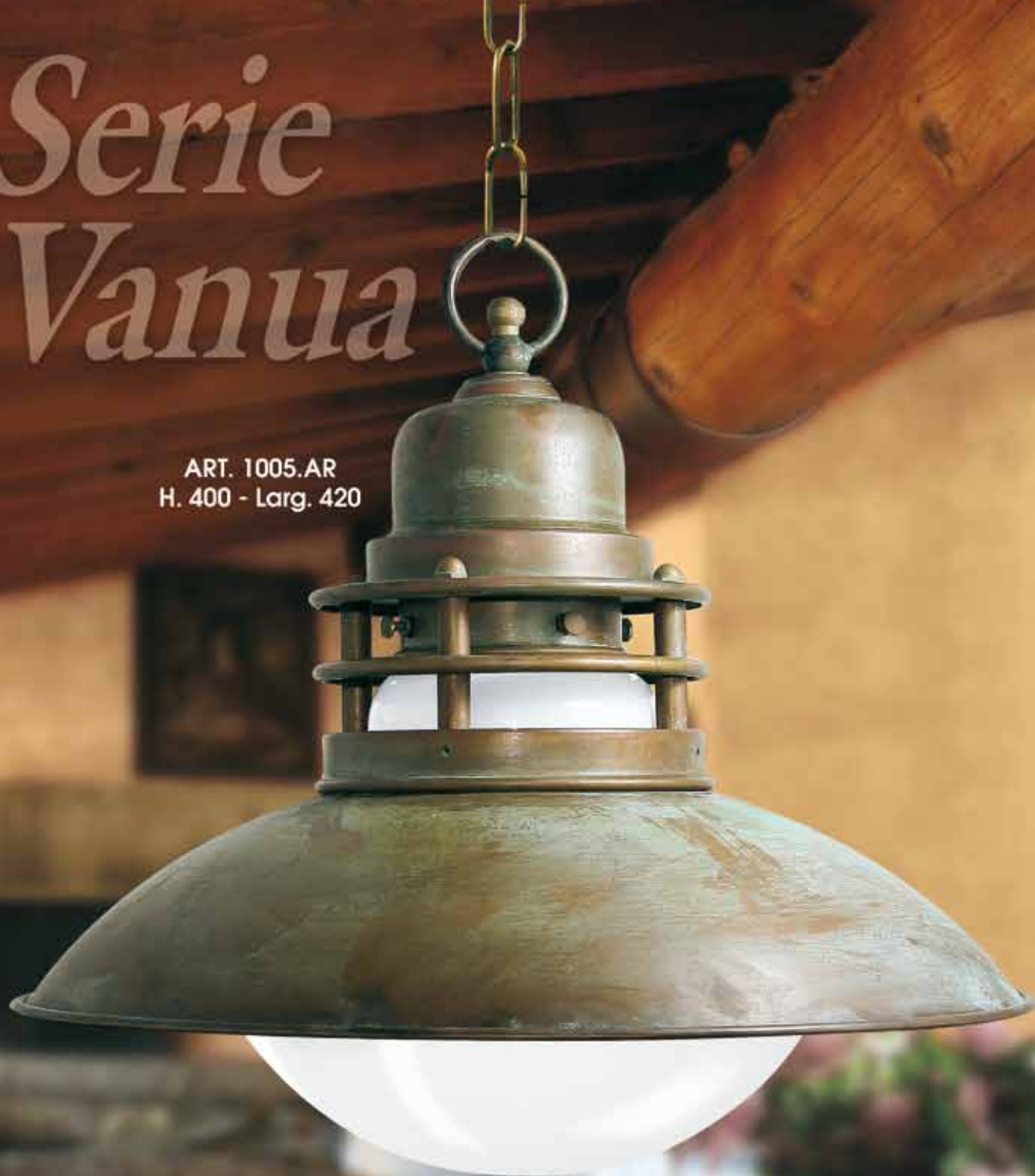

IP 20  E 27  Max Watt 100  20/23 Watt

Finitura ottone
Finition laiton
Brass finishes

.A.AR.V

Colore vetri
Couleurs des opalines
Glass colours

.O = opale
.T = trasparente



ART. 1615.AR
H. 420 - Prof. 240
Paterre Ø 105



ART. 1616.AR
H. 360 - Larg. 210

Serie Guadalupa

IP 20  E 27

 Max Watt 100  20/23 Watt

Finitura ottone
Finition laiton
Brass finishes

.A.AR.V

Guadalupa

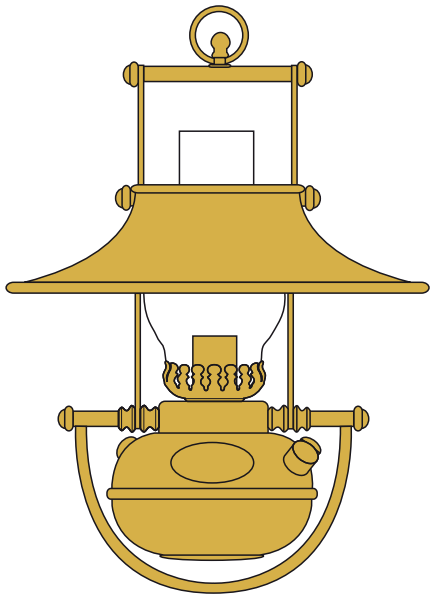

ART. 1606
H. 540 - Larg. 400
Max 100 Watt

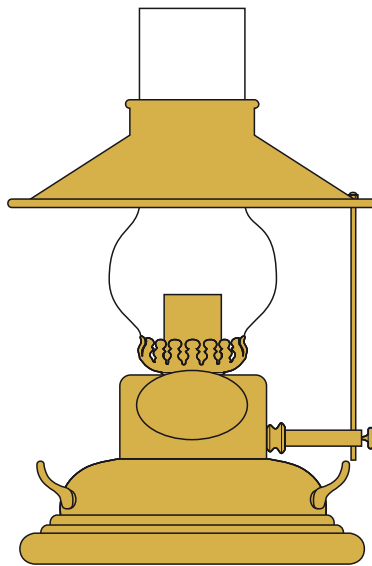

ART. 1616
H. 360 - Larg. 210
Max 100 Watt

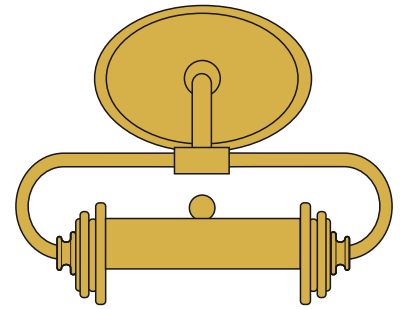

ART. 1625
H. 260 - Larg. 330 - Prof. 150

 11 Watt elettronica

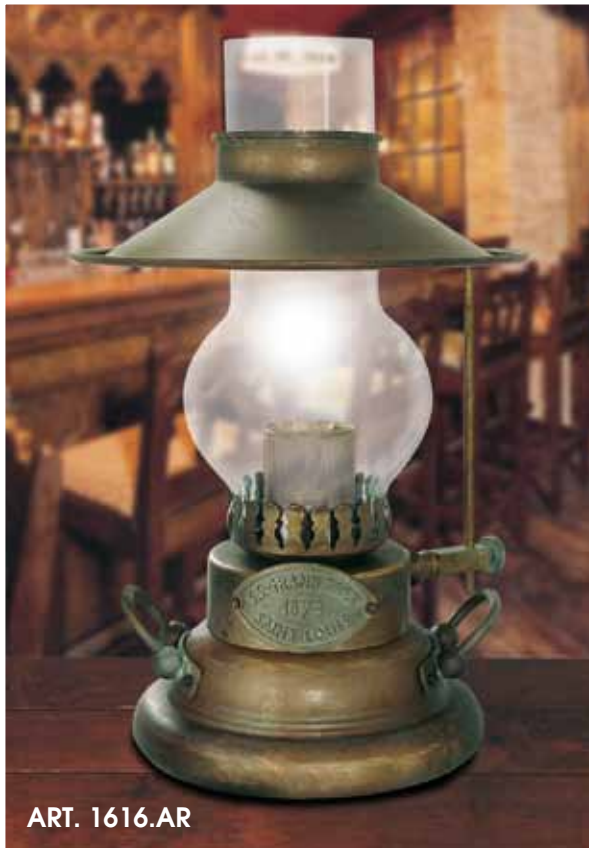

ART. 1616.AR



ART. 1625.AR

Finitura ottone
Finition laiton
Brass finishes

.A.V.AR.BA



Guadalupa

ART. 1606.AR

Country

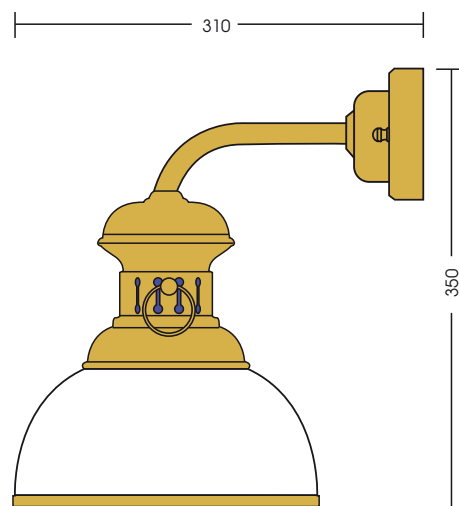

ART. 1008
Vetro Ø 250 - Larg. 250
Max Watt 60

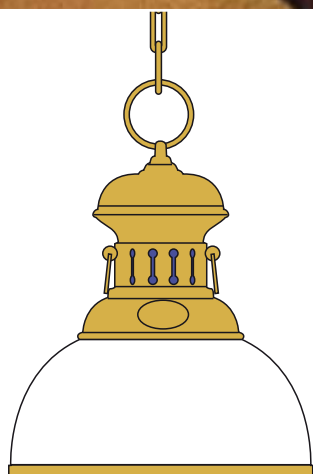

ART. 1010
Vetro Ø 250 - H. 370

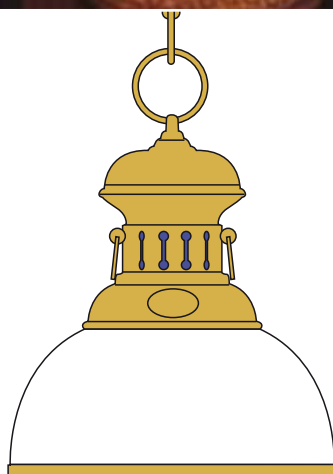

ART. 1011
Vetro Ø 300 - H. 400

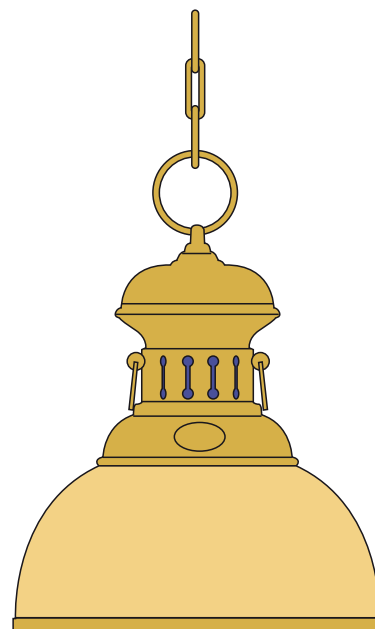

ART. 1013
Vetro Ø 400 - H. 450

IP 20  E 27  Max Watt 100

Finitura ottone
Finition laiton
Brass finishes

.A.V.AR.BA

Art. 1011.A.6



Country



Art. 1011.V.6

Solaris

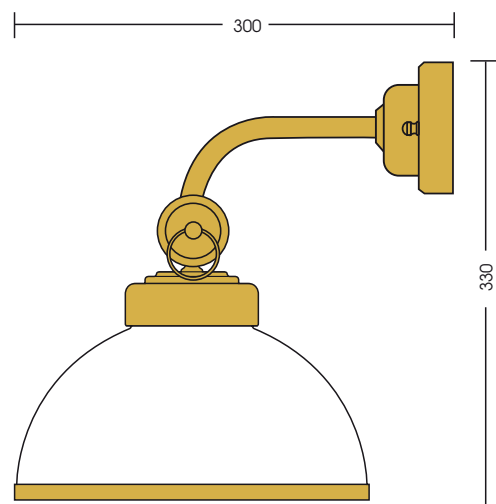

ART. 1018
Vetro Ø 250 - Larg. 250
Max Watt 60

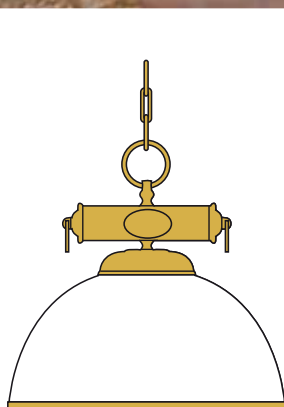

ART. 1020
Vetro Ø 250 - H. 310

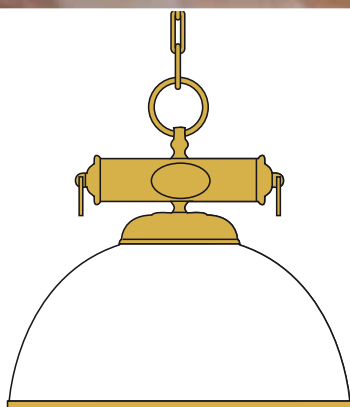

ART. 1021
Vetro Ø 300 - H. 340

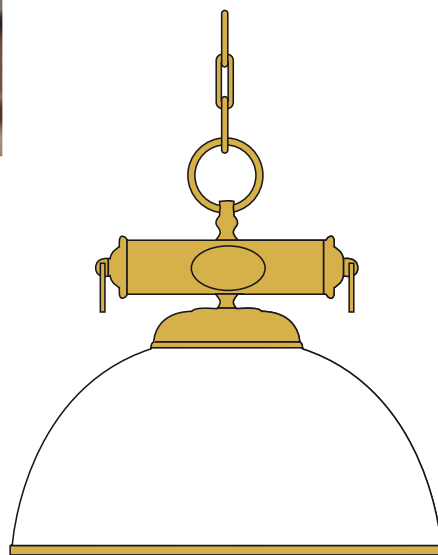

ART. 1023
Vetro Ø 400 - H. 380

IP 20



E 27



Max Watt 100

Finitura ottone
Finition laiton
Brass finishes

.A.V.AR.BA

Art. 1023.V.6



Solaris

Solaris

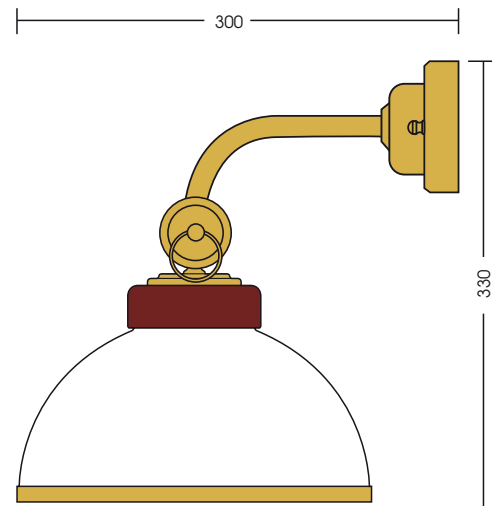

ART. 1123
Vetro Ø 250 - Larg. 250
Max Watt 60

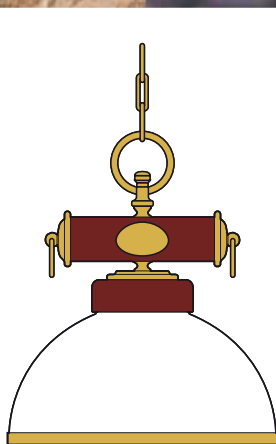

ART. 1125
Vetro Ø 250 - H. 280

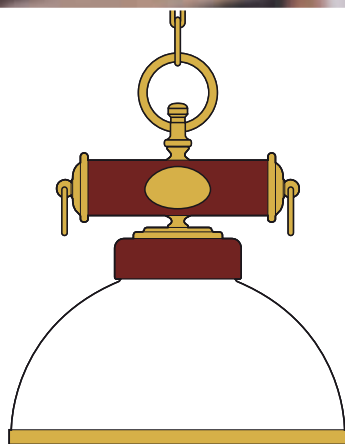

ART. 1126
Vetro Ø 300 - H. 310

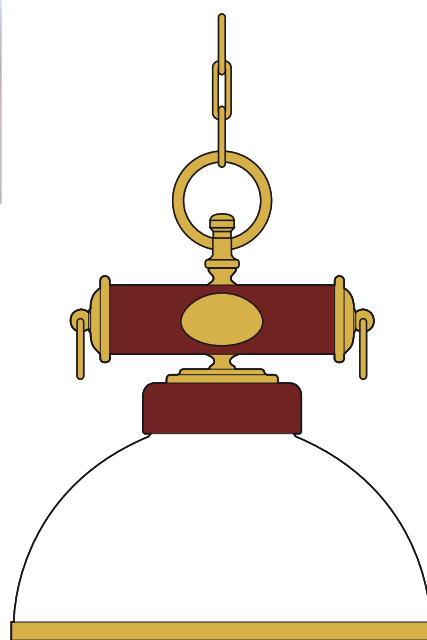

ART. 1128
Vetro Ø 400 - H. 350

IP 20  E 27  Max Watt 100

Finitura ottone
Finition laiton
Brass finishes

.A.V.AR.BA

Art. 1126.A.7



Solaris

Art. 1126.V.6



Madeira

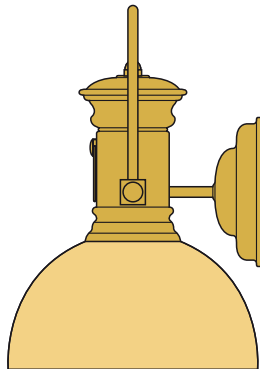

ART. 1105
Ø 200
H. 240 - Prof. 205
Max Watt 60

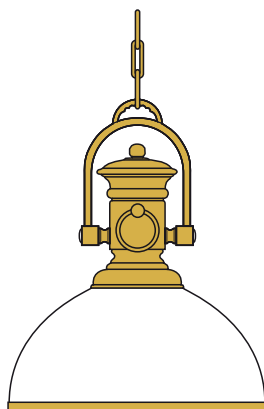

ART. 1102
Vetro Ø 250 - H. 300

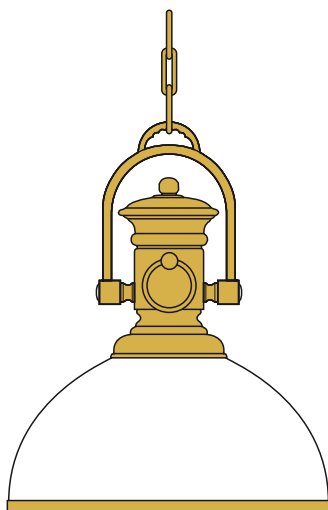

ART. 1103
Vetro Ø 300 - H. 340

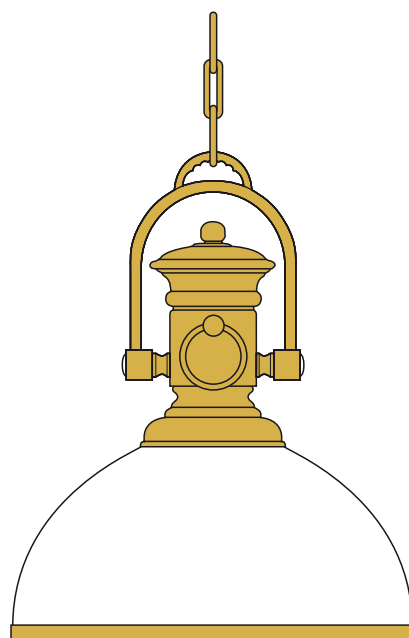

ART. 1104
Vetro Ø 400 - H. 430

IP 20



E 27



Max Watt 100

Finitura ottone
Finition laiton
Brass finishes

.A.V.AR.BA



ART. 1104.A.6



ART. 1105.AR.6

Madeira

Madeira

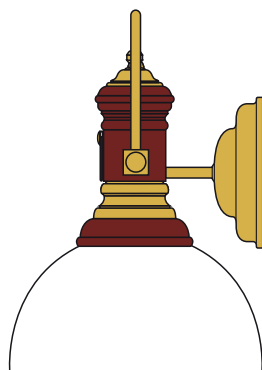

ART. 1106
Vetro Ø 200
H. 240 - Prof. 205
Max Watt 60

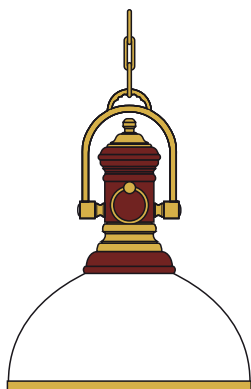

ART. 1107
Vetro Ø 250 - H. 300

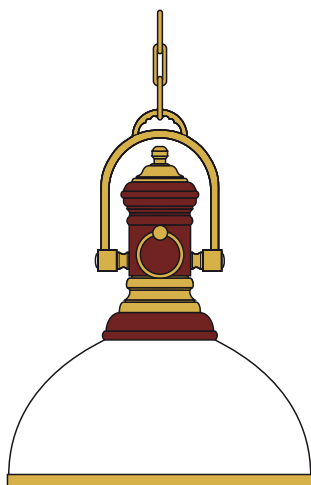

ART. 1108
Vetro Ø 300 - H. 340

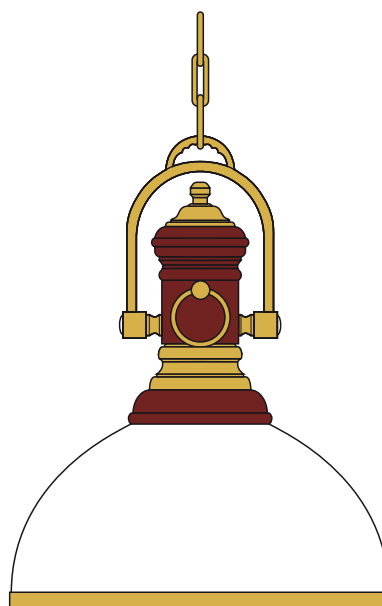

ART. 1109
Vetro Ø 400 - H. 430

IP 20



E 27



Max Watt 100

Finitura ottone
Finition laiton
Brass finishes

.A.V.AR.BA



ART. 1108.V.7

Madeira

Grenville

OTTONE

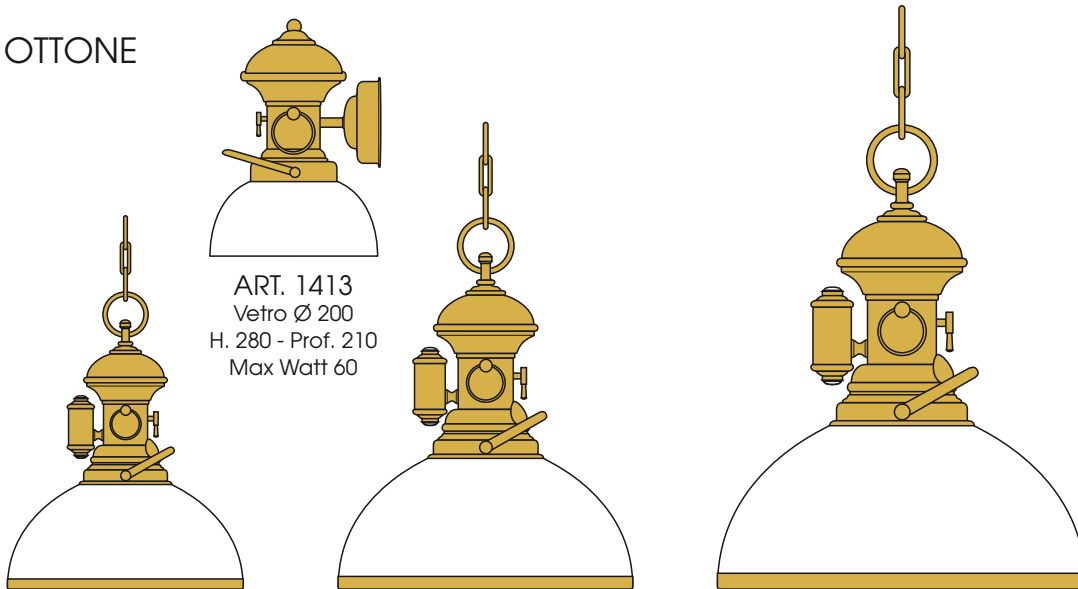

ART. 1413
Vetro Ø 200
H. 280 - Prof. 210
Max Watt 60

ART. 1415
Vetro Ø 250 - H. 330

ART. 1416
Vetro Ø 300 - H. 390

ART. 1417
Vetro Ø 400 - H. 500

Sospensione fissa
ART. 1415F
ART. 1416F
ART. 1417F

OTTONE CON LEGNO

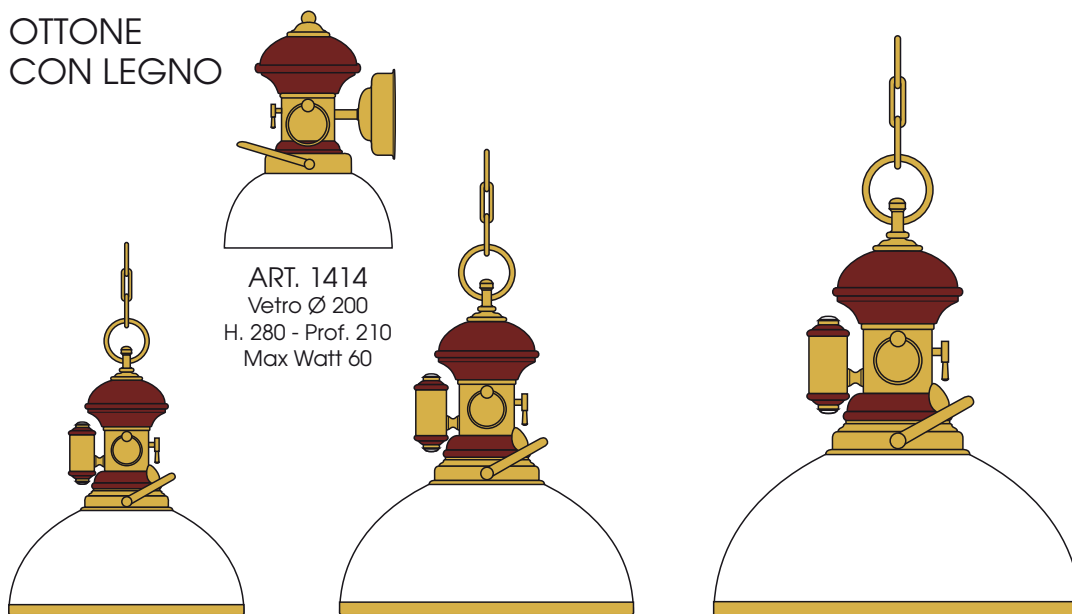

ART. 1414
Vetro Ø 200
H. 280 - Prof. 210
Max Watt 60

ART. 1418
Vetro Ø 250 - H. 330

ART. 1419
Vetro Ø 300 - H. 390

ART. 1420
Vetro Ø 400 - H. 500

Sospensione fissa
ART. 1418F
ART. 1419F
ART. 1420F

IP 20  E 27  Max Watt 100

Finitura ottone
Finition laiton
Brass finishes

.A.V.AR.BA

ART. 1420.V.8



ART. 1414.V.6



ART. 1419.A.6

Grenville

Freeport

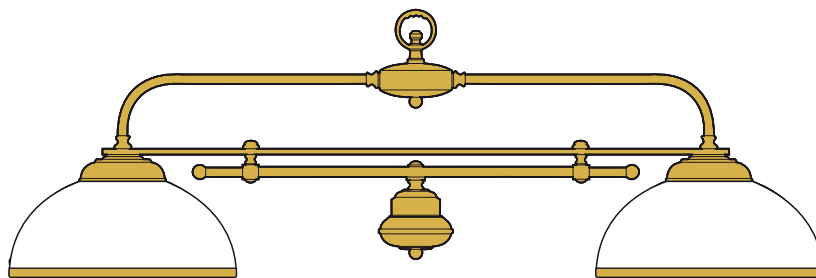

ART. 1582
Vetro Ø 300 - H. 360 - Larg. 1100

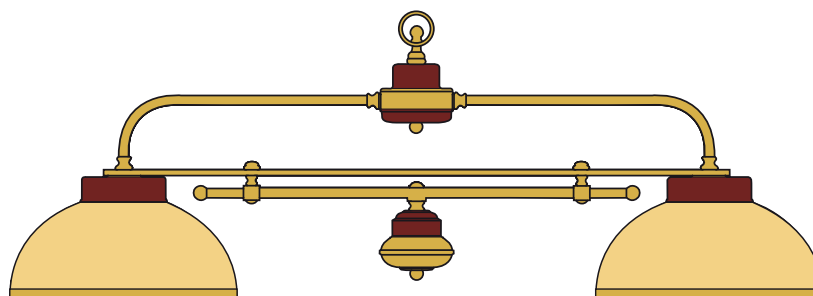

ART. 1583
Vetro Ø 300 - H. 360 - Larg. 1100

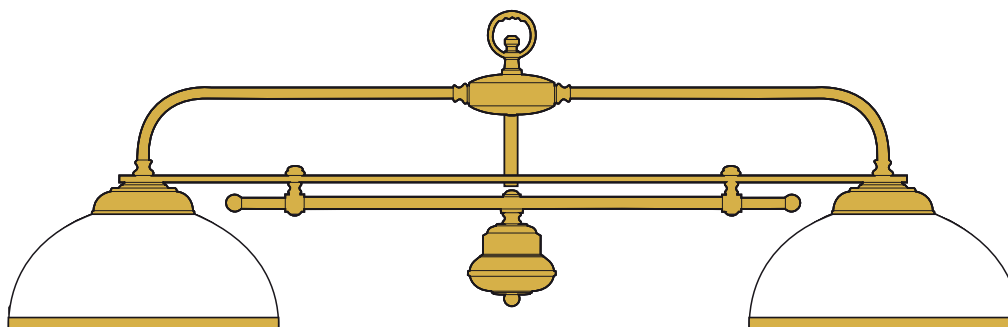

ART. 1584
Vetro Ø 400 - H. 450 - Larg. 1400

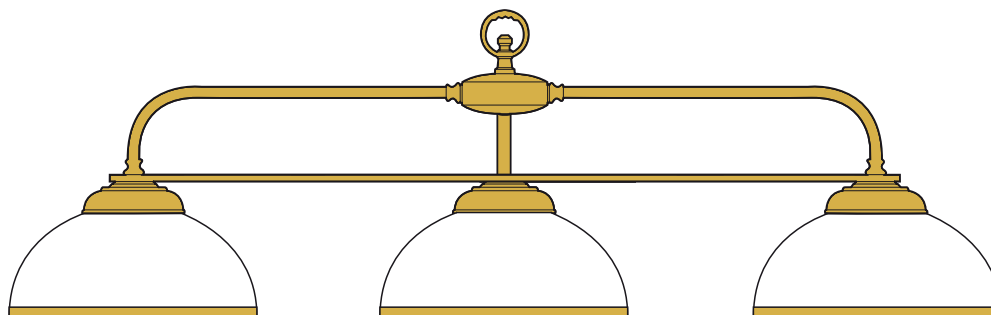

ART. 1585
Vetro Ø 300 - H. 360 - Larg. 1310

IP 20



E 27



Max Watt 100

Finitura ottone
Finition laiton
Brass finishes

.A.V.AR.BA

ART. 1582.V.8



ART. 1583.V.7



Spotisland

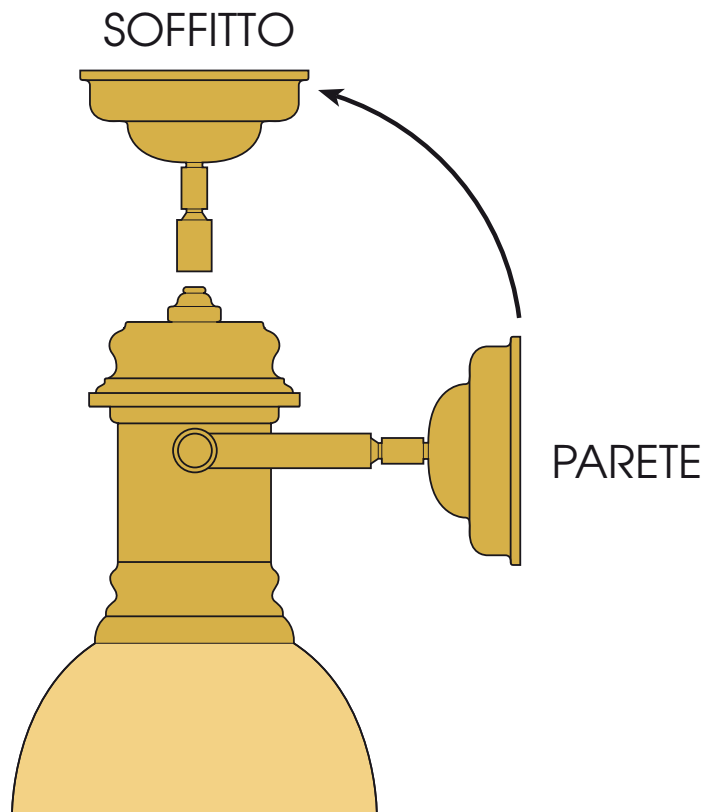

ART. 1522
Vetro Ø 145
H. 230 - Prof. 145

IP 20  E 27  Max Watt 60

Finitura ottone
Finition laiton
Brass finishes

.A.V.AR.BA



ART. 1522.AR.7

Spotisland

Spotisland

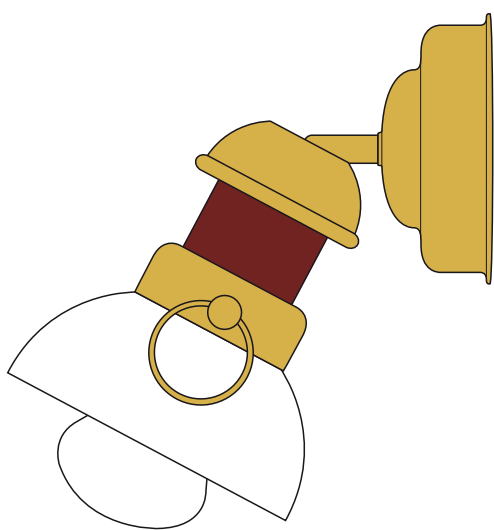

ART. 1528
Vetro Ø 120 - H. 210 - Larg. 120

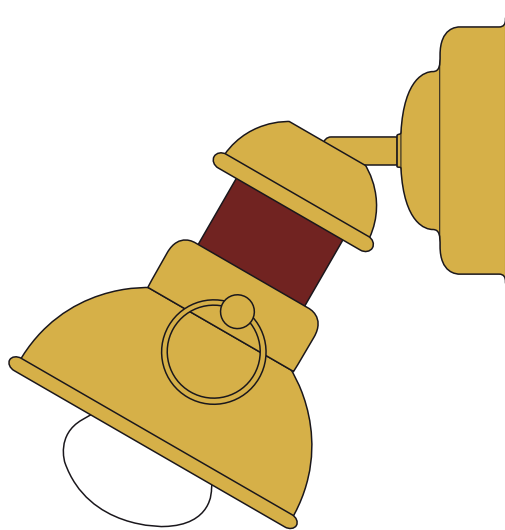

ART. 1529
Vetro Ø 120 - H. 220 - Larg. 120

IP 20



E 27



Max Watt 60

Finitura ottone
Finition laiton
Brass finishes

.A.V.AR.BA



ART. 1529.V

Spotisland



ART. 1528.V.8

Bahia

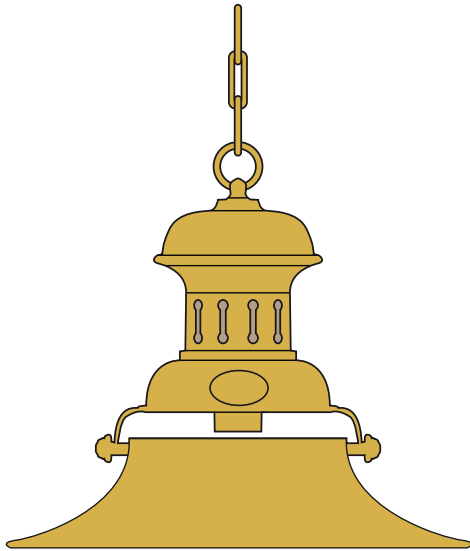

ART. 1006
Ø 40 - H. 35

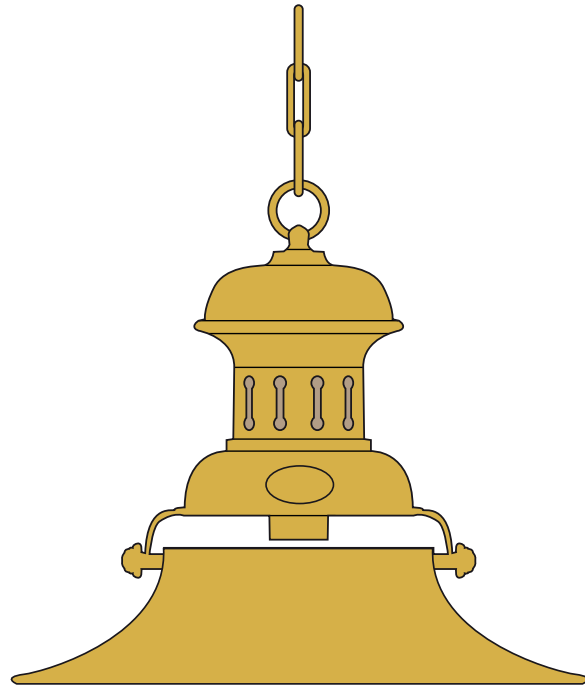

ART. 1007
Ø 50 - H. 41

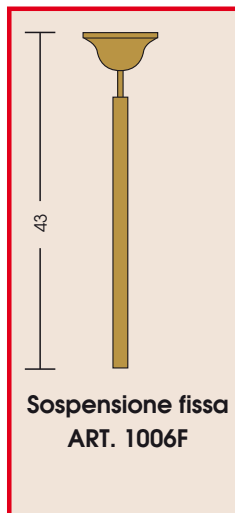

Sospensione fissa
ART. 1006F

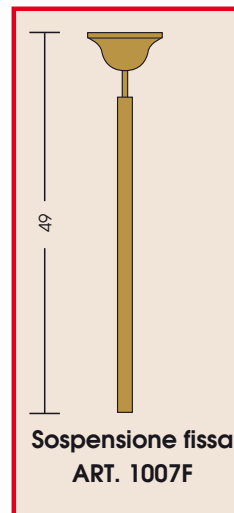

Sospensione fissa
ART. 1007F

IP 20



E 27



Max Watt 100

Finitura ottone
Finition laiton
Brass finishes

A.AR.V.BA

ART. 1006.AR



Bahia

Mariner

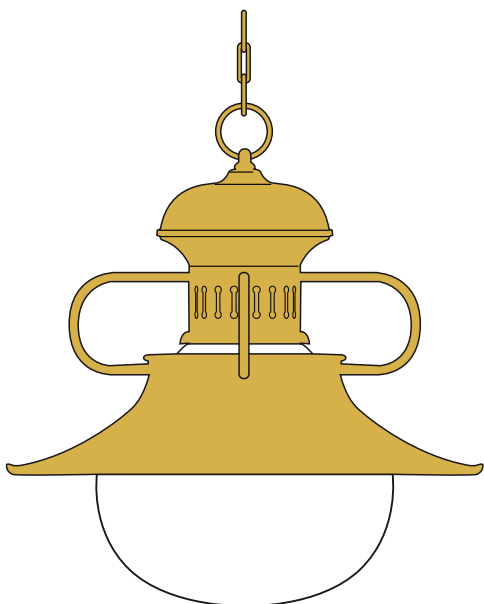

ART. 1050
Ø 400 - H.450

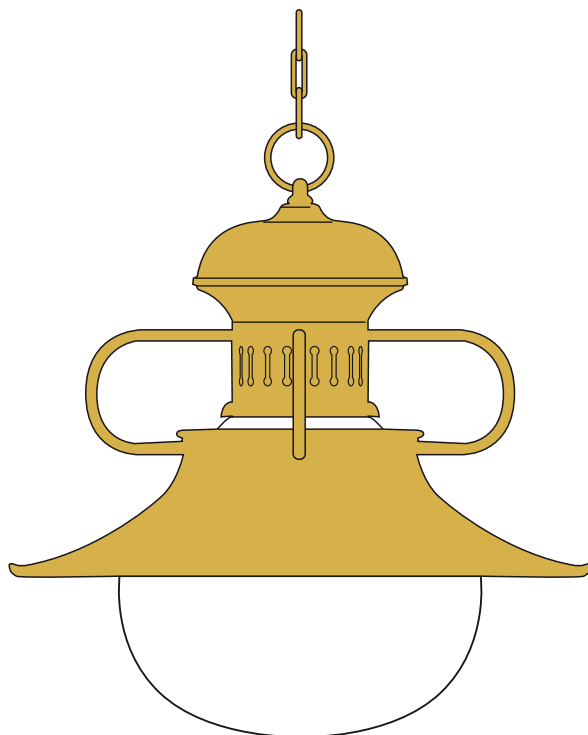

ART. 1051
Ø 550 - H.500

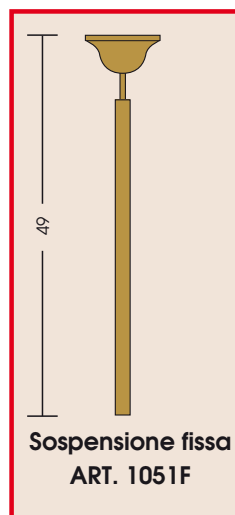
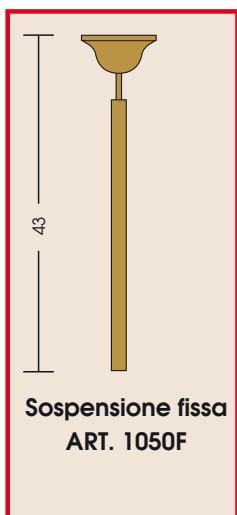

IP 20



E 27



Max Watt 100

Finitura ottone
Finition laiton
Brass finishes

.A.V.AR.BA



Mariner

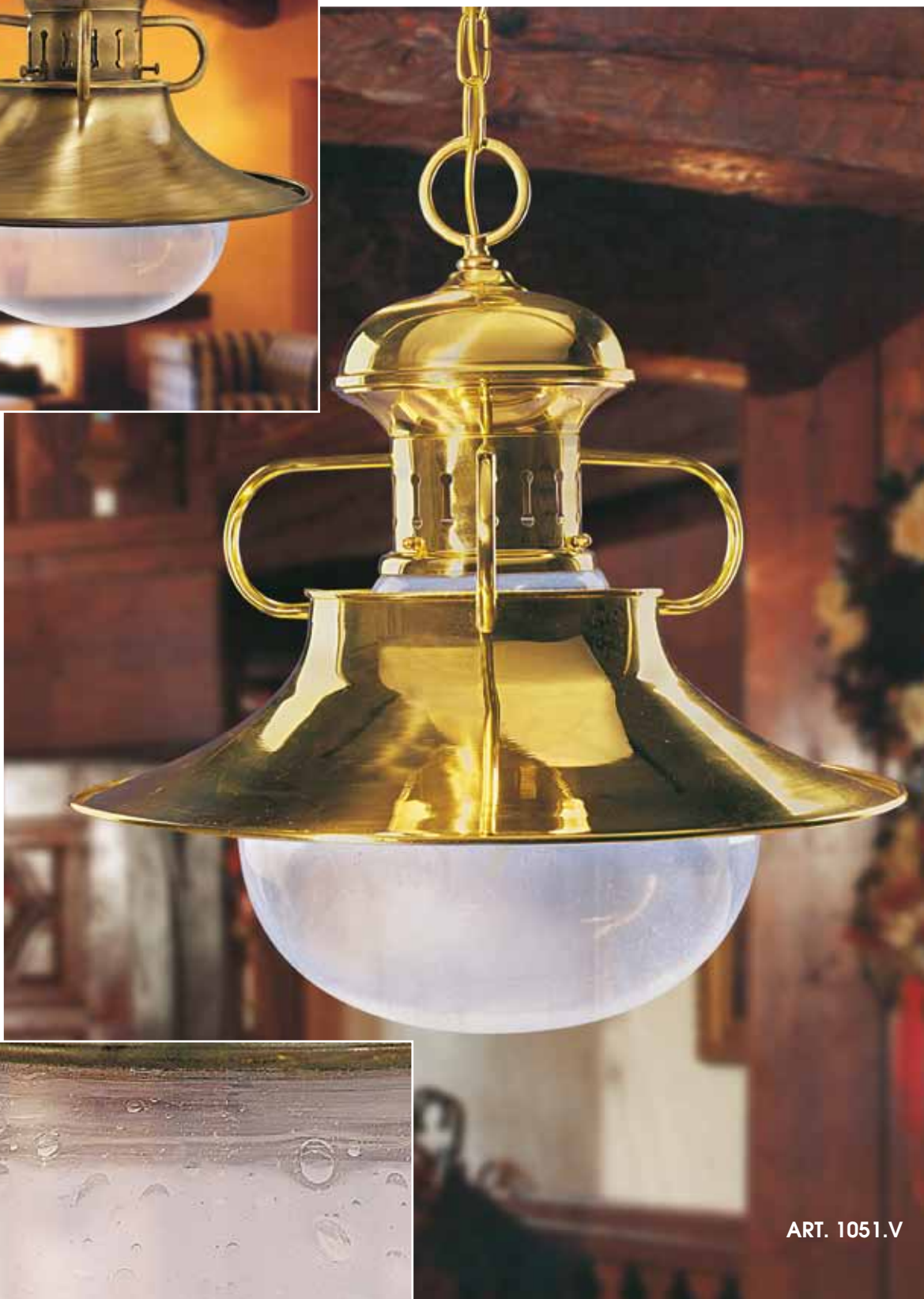

Nautilus

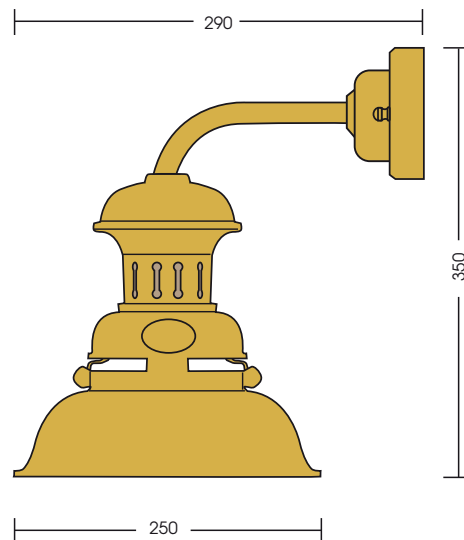

ART. 1058

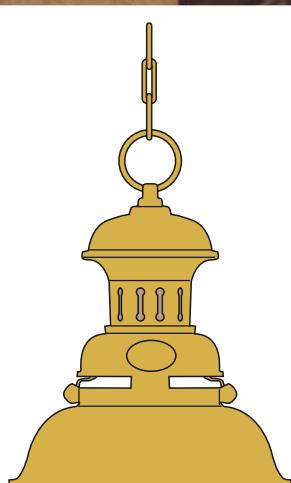

ART. 1060
Ø 250 - H. 310

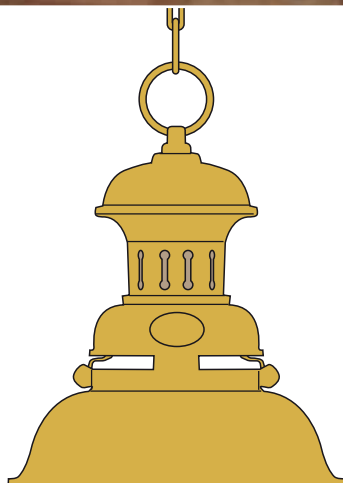

ART. 1061
Ø 300 - H. 370

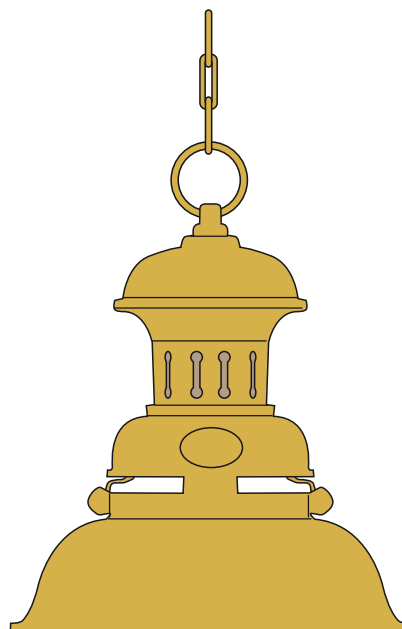

ART. 1062
Ø 400 - H. 440

IP 20  E 27  Max Watt 100

Finitura ottone
Finition laiton
Brass finishes

.A.V.AR.BA

ART. 1061.A



Nautilus



ART. 1062.V

Galleon



Art. 1098.AR

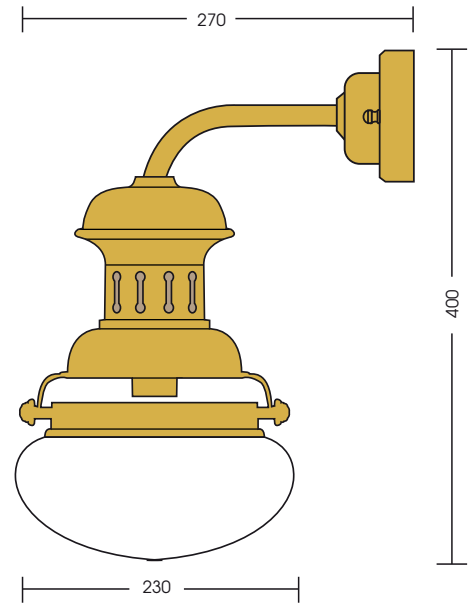

ART. 1098

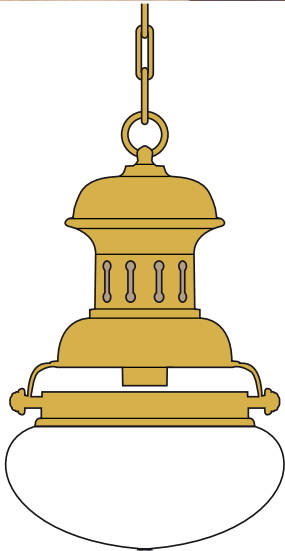

ART. 1100
Vetro Ø 250 - H.330

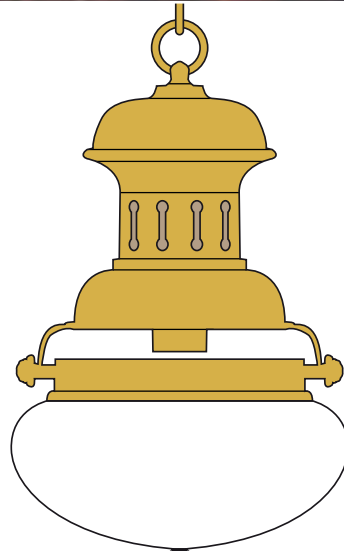

ART. 1101
Vetro Ø 300 - H.400

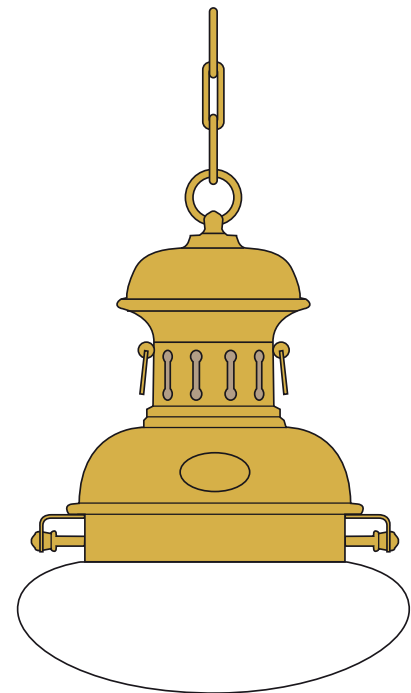

ART. 1112
Vetro Ø 430 - H.530
Max Watt 2 x 60

IP 20



E 27



Max Watt 100

Finitura ottone
Finition laiton
Brass finishes

.A.V.AR.BA

Galleon

Art. 1112.V



Art. 1112.AR



Vetro trasparente bulicoso - Bubble air transparent glass

Wind

Sospensioni fisse (F)

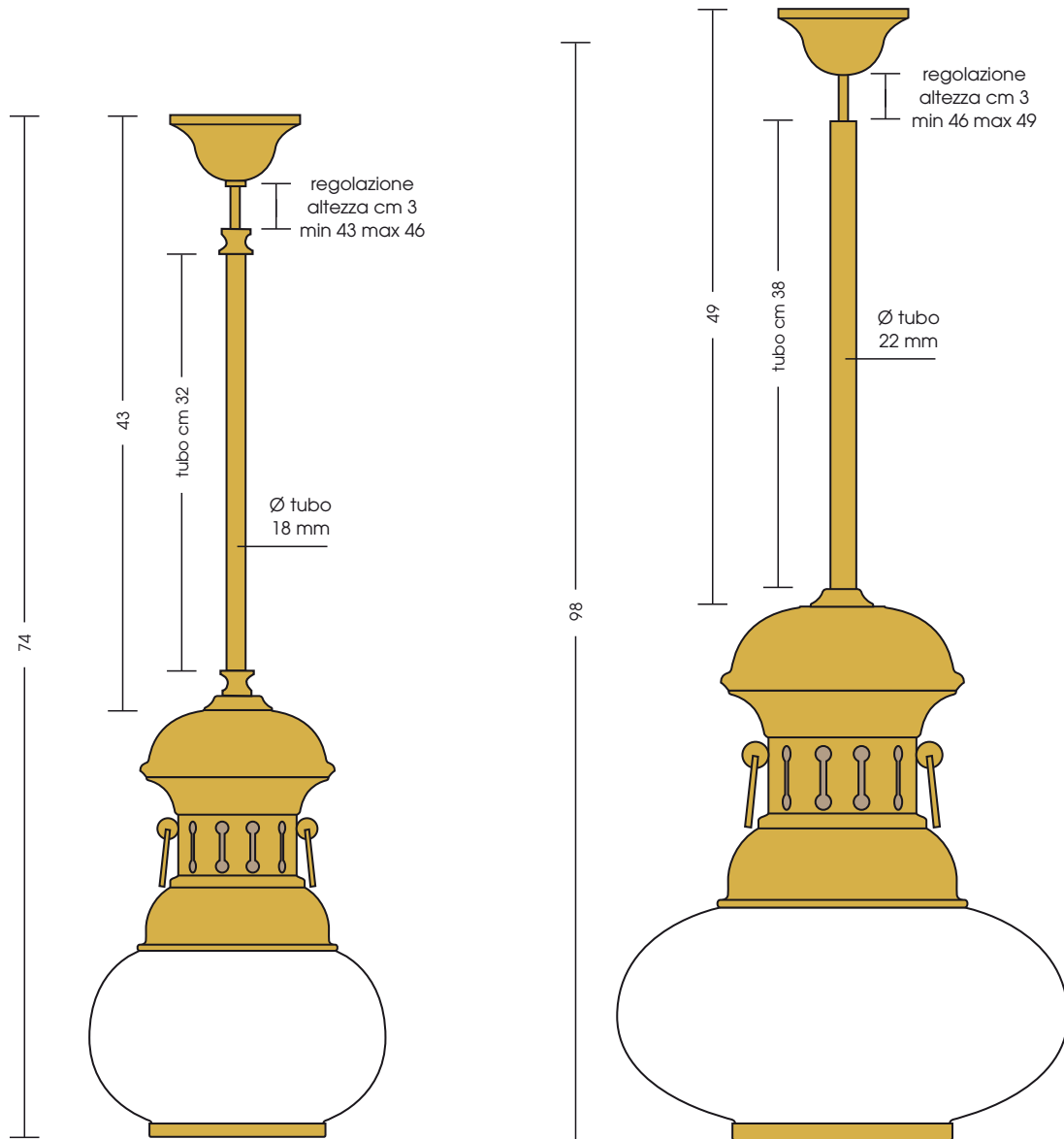

ART. 1600F.AR
Vetro Ø 220 - H. 340
Max Watt 75

ART. 1601F.AR
Vetro Ø 430 - H. 570
Max Watt 100

N.B. a richiesta su tutte le sospensioni fisse il tubo di cm 32 può essere fornito anche di cm 16
a richiesta su tutte le sospensioni fisse il tubo di cm 38 può essere fornito anche di cm 19

IP 20



Finitura ottone
Finition laiton
Brass finishes

.A.V.AR.BA



Art. 1600F.AR



Art. 1601F.AR



Vetro trasparente bulicoso - Bubble air transparent glass

Wind

Wind

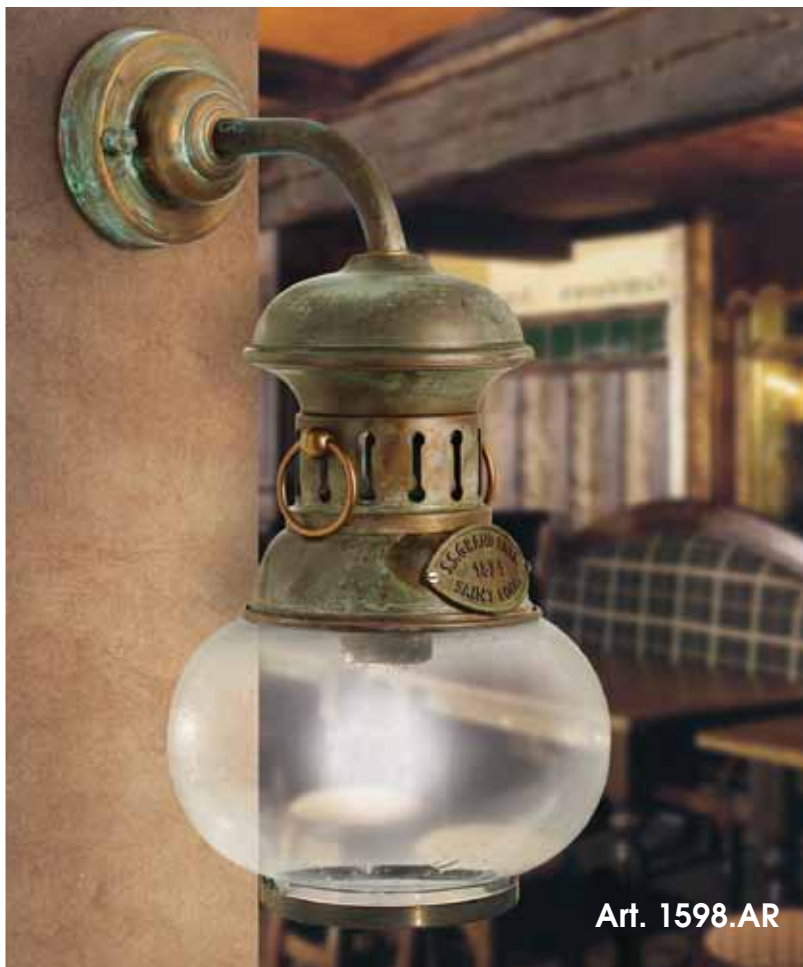

Art. 1598.AR

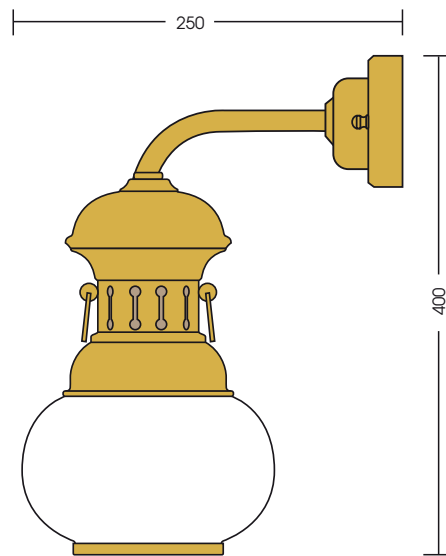

ART. 1598 - Max Watt 75

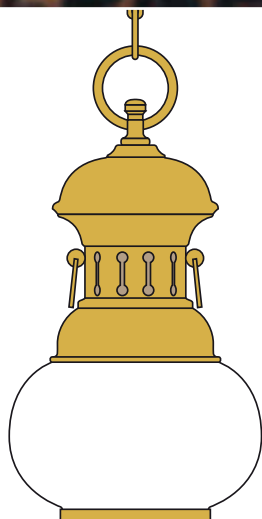

ART. 1600
Vetro Ø 220 - H. 340
Max Watt 75

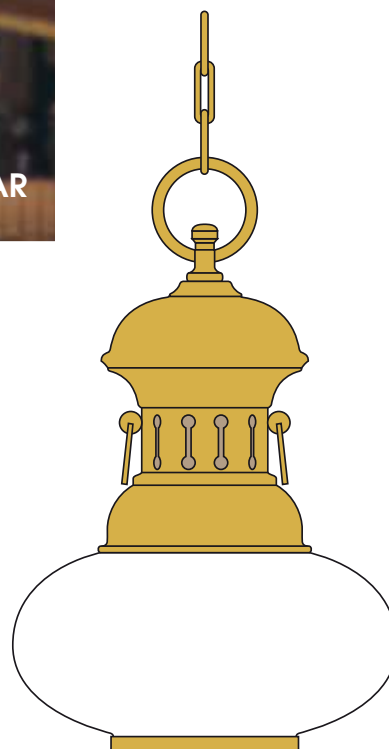

ART. 1601
Vetro Ø 430 - H. 570
Max Watt 100

IP 20  E 27 

Finitura ottone
Finition laiton
Brass finishes

.A.V.AR.BA



Art. 1600.V



Vetro trasparente bulicoso - Bubble air transparent glass

Wind

Wind

OTTONE

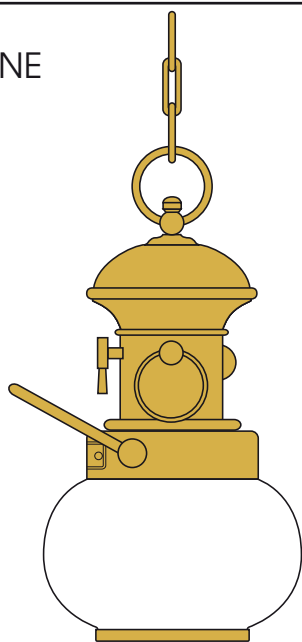

ART. 1640
Vetro Ø 165 - H. 360

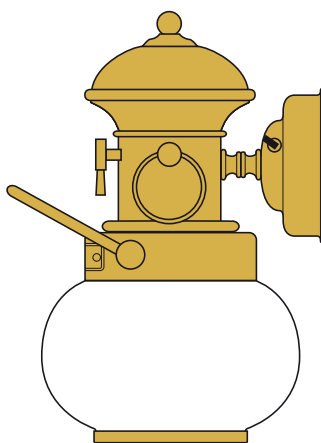

ART. 1639
Vetro Ø 165 - H. 320 - Prof. 180

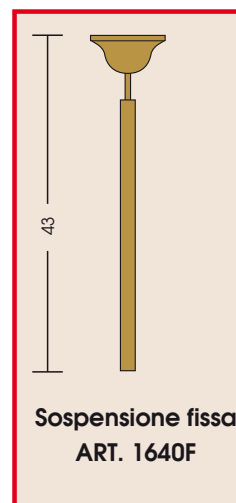

OTTONE
CON LEGNO

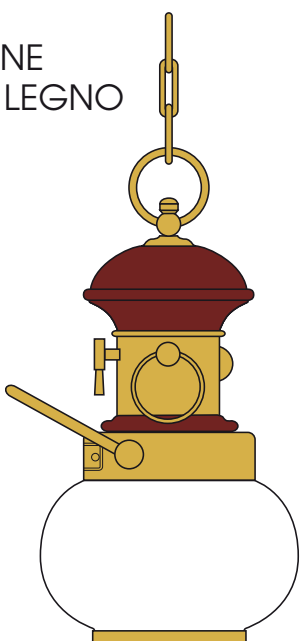

ART. 1642
Vetro Ø 165 - H. 360

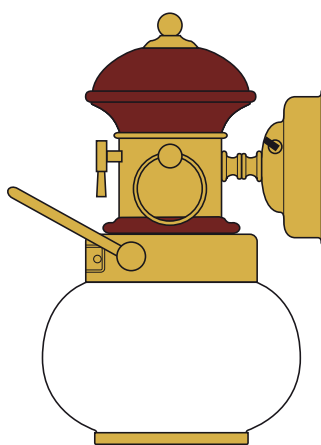

ART. 1641
Vetro Ø 165 - H. 310 - Prof. 180

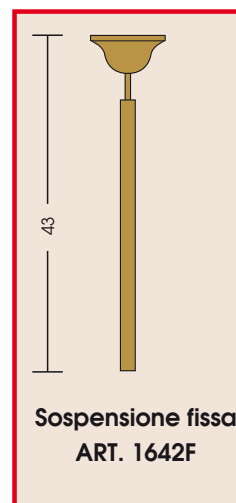

IP 20



E 27



Max Watt 75

Finitura ottone
Finition laiton
Brass finishes

.A.V.AR.BA

Wind



Art. 1640.V



Art. 1639.AR



Art. 1641.V



Vetro trasparente bulicoso - Bubble air transparent glass

Martinica

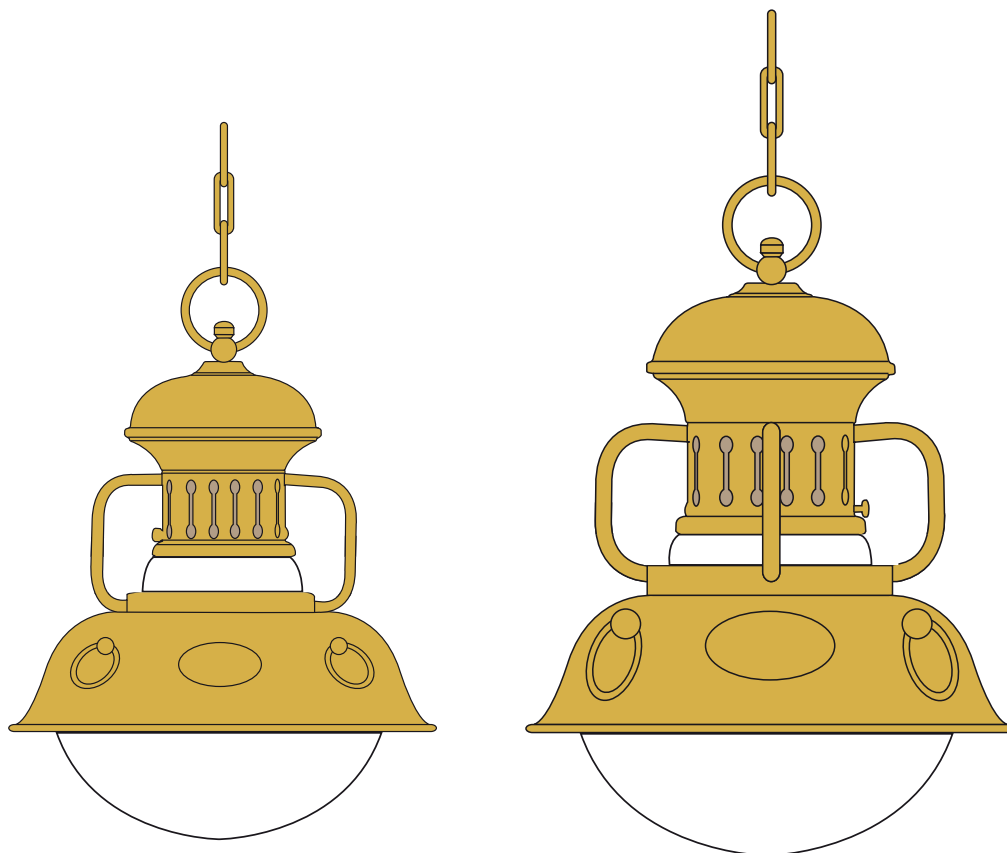

ART. 1607
H. 400 - Larg. 320

ART. 1608
H. 530 - Larg. 410

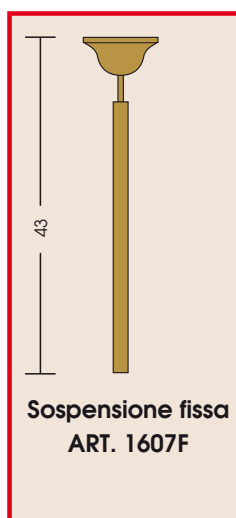

Sospensione fissa
ART. 1607F

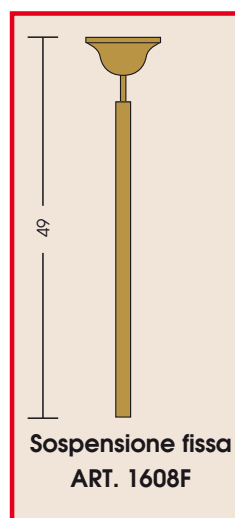

Sospensione fissa
ART. 1608F

IP 20



E 27



Max Watt 100

Finitura ottone
Finition laiton
Brass finishes

.A.V.AR.BA

Martinica

ART. 1608.V



ART. 1608.BA



ART. 1607.A



Vetro trasparente bulicoso - Bubble air transparent glass

Aves

OTTONE

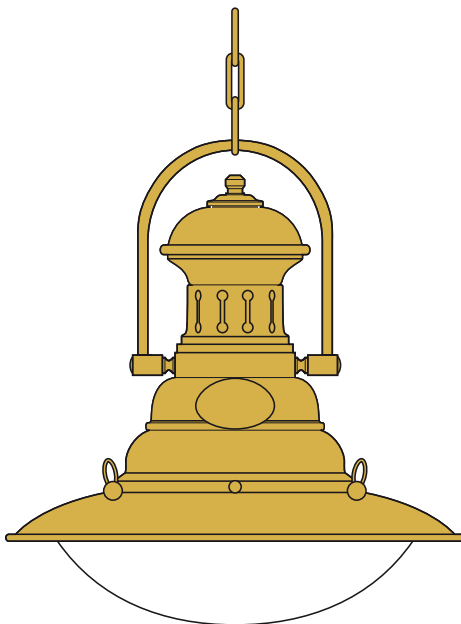

ART. 1578
Ø 400 - H. 500

OTTONE
CON LEGNO

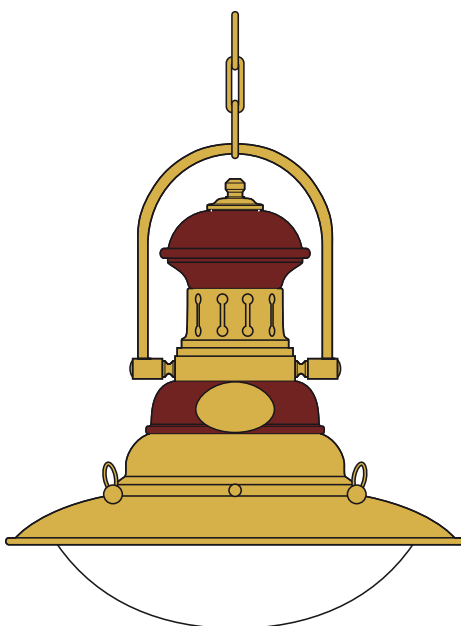

ART. 1579
Ø 400 - H. 500

IP 20  E 27  Max Watt 100

Finitura ottone
Finition laiton
Brass finishes

.A.V.AR.BA



ART. 1578.V



ART. 1579.V



ART. 1578.A

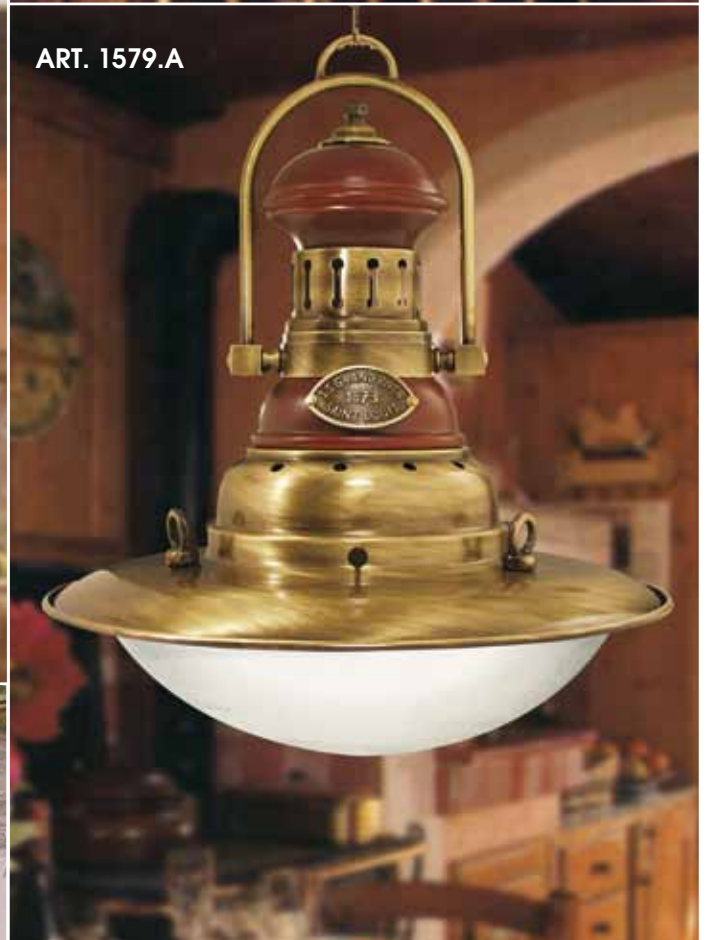

ART. 1579.A



Vetro trasparente bulicoso - Bubble air transparent glass

Aves

Espada

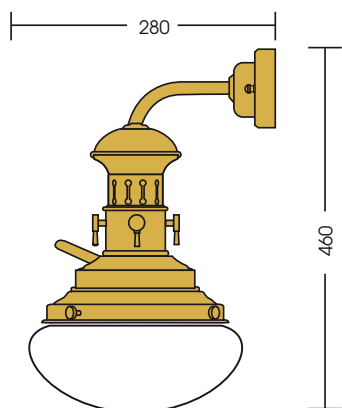

ART. 1576
Vetro Ø 250
Larg. 250

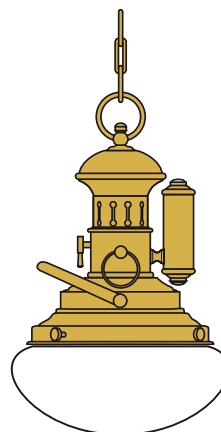

ART. 1570
Vetro Ø 250
H. 390 - Larg. 240

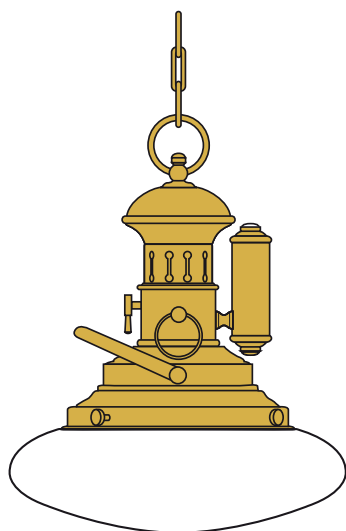

ART. 1571
Vetro Ø 300
H. 430 - Larg. 320

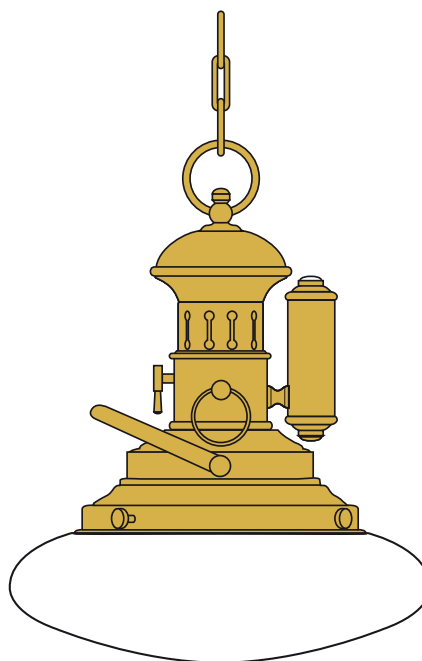

ART. 1572
Vetro Ø 450
H. 450 - Larg. 450

IP 20



E 27



Max Watt 100

Finitura ottone
Finition laiton
Brass finishes

.A.V.AR.BA

Espada



ART. 1576.AR



ART. 1572.V



Vetro trasparente bulicoso - Bubble air transparent glass

Espada

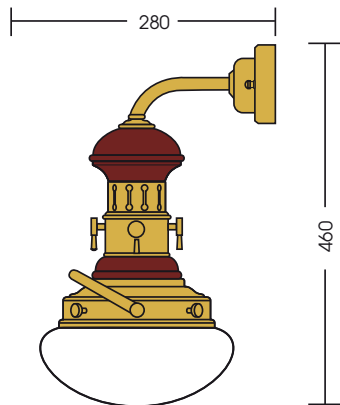

ART. 1577
Vetro Ø 250
Larg. 250

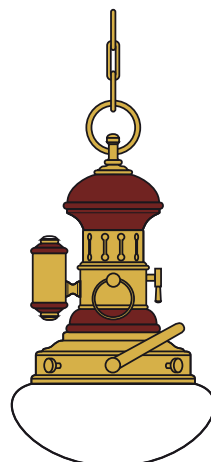

ART. 1573
Vetro Ø 240
H. 390 - Larg. 240

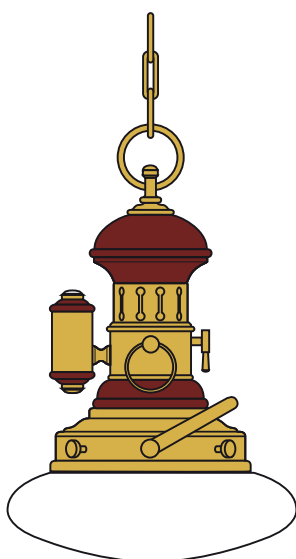

ART. 1574
Vetro Ø 300
H. 430 - Larg. 320

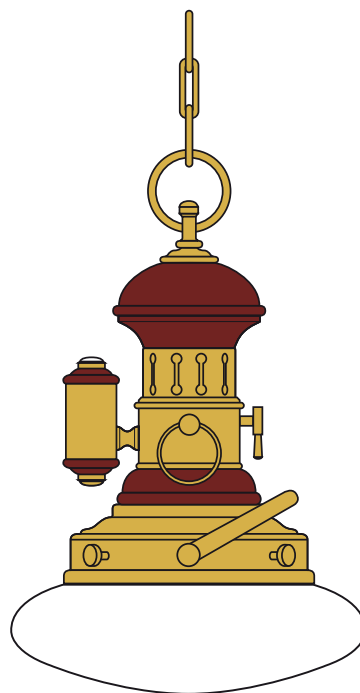

ART. 1575
Vetro Ø 450
H. 450 - Larg. 450

IP 20



E 27



Max Watt 100

Finitura ottone
Finition laiton
Brass finishes

.A.V.AR.BA

Espada



ART. 1577.AR



ART. 1573.V



Vetro trasparente bulicoso - Bubble air transparent glass

Merida

OTTONE

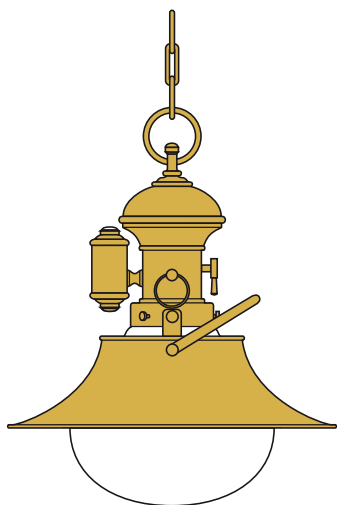

ART. 1152
Ø 250
H. 450 - Larg. 405

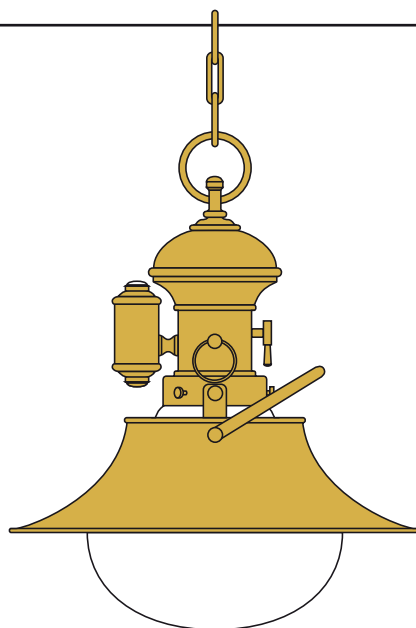

ART. 1153
Ø 300
H. 500 - Larg. 500

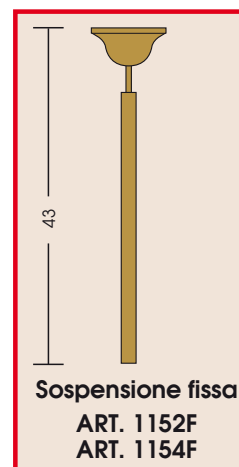

OTTONE
CON LEGNO

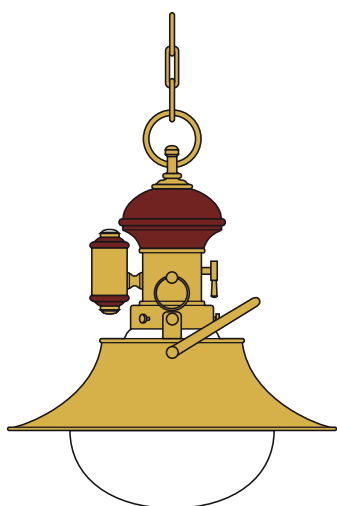

ART. 1154
Ø 250
H. 450 - Larg. 405

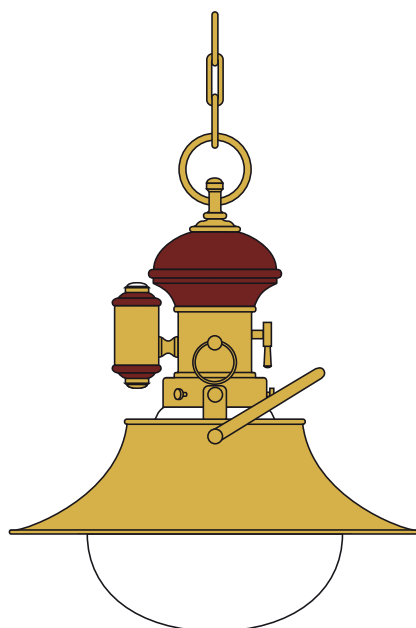

ART. 1155
Ø 300
H. 540 - Larg. 500

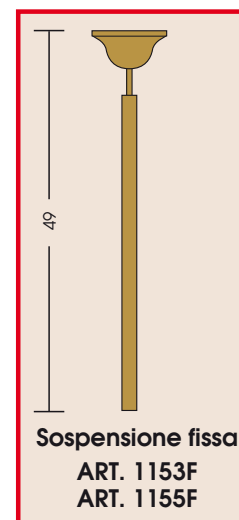

IP 20



E 27



Max Watt 100

Finitura ottone
Finition laiton
Brass finishes

.A.V.AR.BA

Merida



ART. 1153.V



ART. 1154.AR



Vetro trasparente bulicoso - Bubble air transparent glass

Oblò luce

APPLIQUES PER INTERNI / APPLIQUES POUR INTÉRIEUR
INDOOR BRACKET-LAMP / WANDLEUCHTE FÜR DEN INNENRAUM

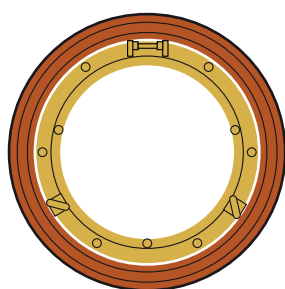

250
300

ART. 200.07
ART. 200.07.A
ART. 200.07.AR

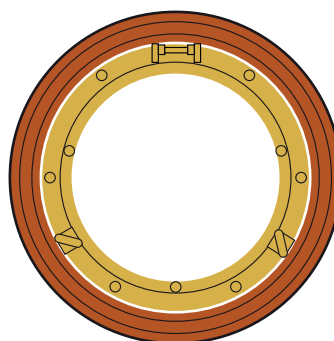

300
360

ART. 200.08
ART. 200.08.A
ART. 200.08.AR

CORPO: Ottone pressofuso e legno - CORPS: Laiton et bois

BODY: Brass and wood - KÖRPER: Messing und holz

DIFFUSORE: Vetro satinato - DIFFUSEUR: Verre satiné

DIFFUSER: Glazed glass - STRAHLER: Satiniertes glas

IP 20



E 27



18 Max Watt

Max Watt 40



Max Watt 60



.A= Ottone brunito (antichizzato)
Laiton vieilli
Brass burnish finishing



ART. 200.08

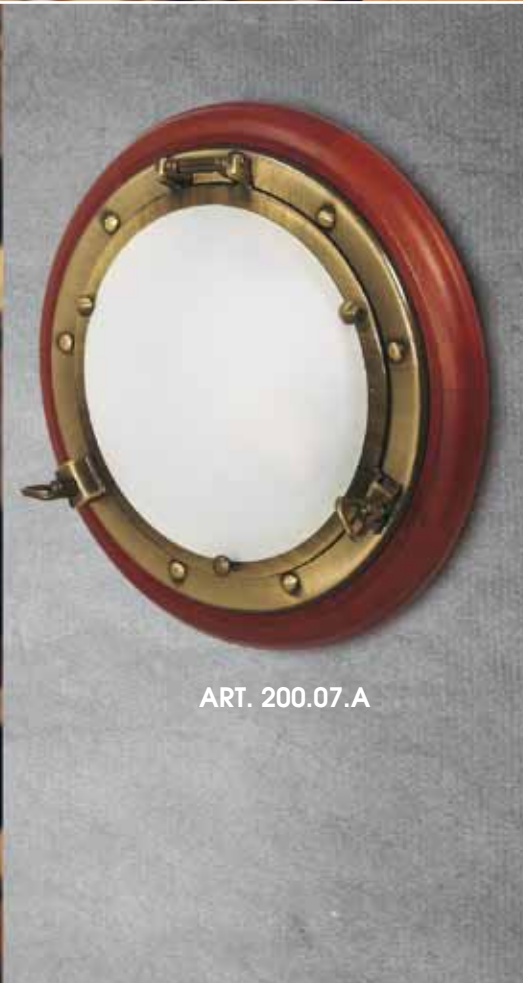

ART. 200.07.A

Oblò luce

Belleville

OTTONE

LAITON

BRASS

MESSING

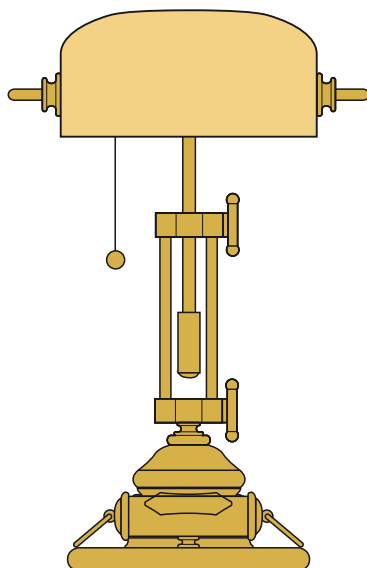

ART. 1506
H. 730 - Larg. 330

OTTONE
CON LEGNO

LAITON AVEC BOIS

BRASS WITH WOOD

MESSING MIT HOLZ

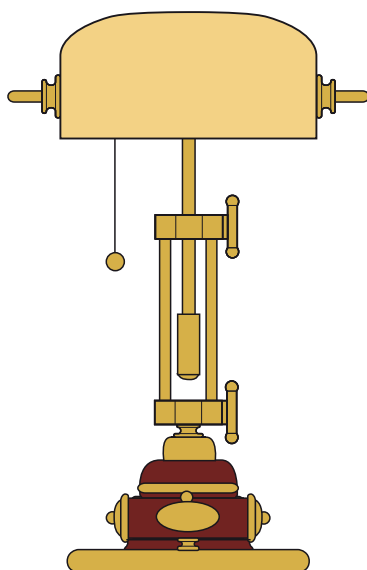

ART. 1507
H. 730 - Larg. 330

IP 20



E 27



Max Watt 100

Finitura ottone
Finition laiton
Brass finishes

.A.D.V.AR



ART. 1506.A.8



ART. 1507.A.6

Belleville

Samoa

OTTONE

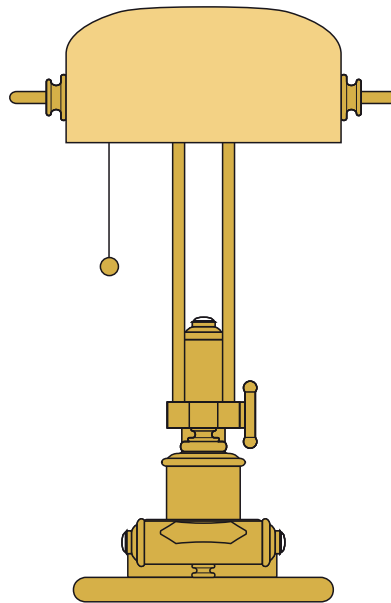

ART. 1512
H. 570 - Larg. 310

OTTONE
CON LEGNO

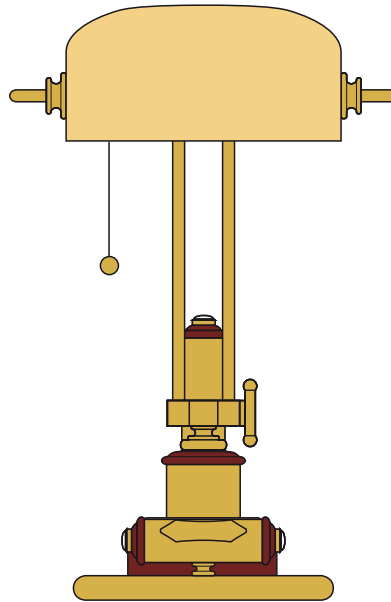

ART. 1513
H. 570 - Larg. 310

IP 20



E 27



Max Watt 100

Finitura ottone
Finition laiton
Brass finishes

.A.D.V.AR

ART. 1513.D.7



ART. 1512.V.6



Samoa

Figi

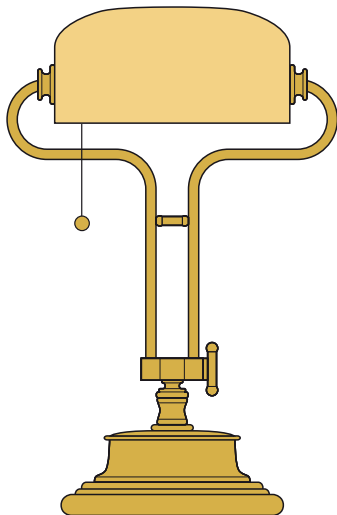

ART. 1509
Base Ø 180
H. 530 - Larg. 320

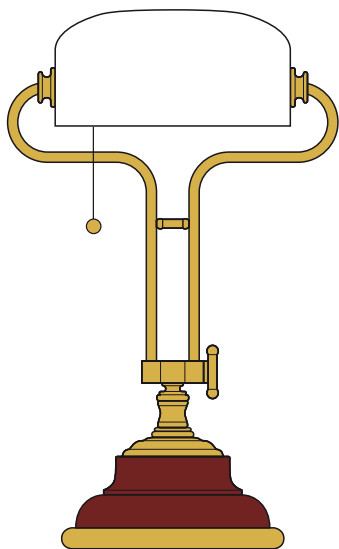

ART. 1511
H. 530 - Larg. 320



IP 20



E 27



Max Watt 100

Finitura ottone
Finition laiton
Brass finishes

.A.D.V.AR



Art. 1509.A.7

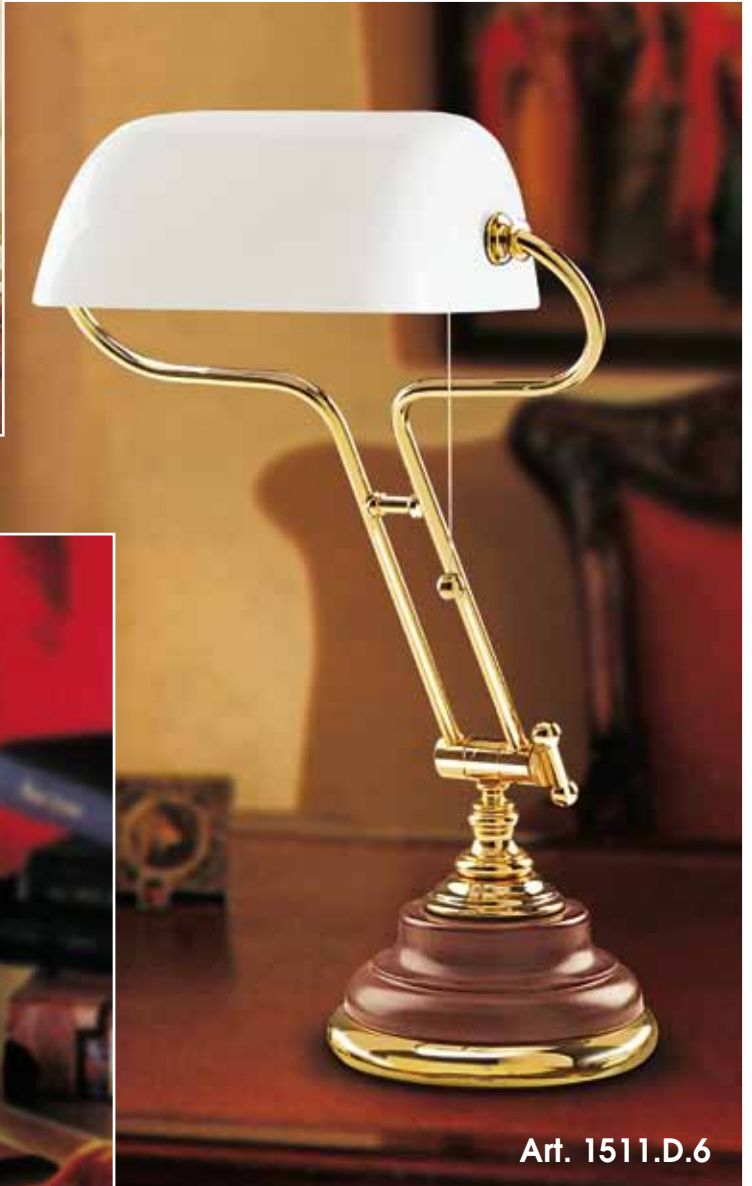

Art. 1511.D.6



Art. 1509.V.8

Figi

Figi

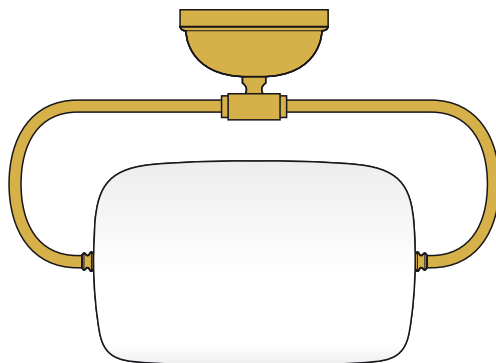

ART. 1500
H. 160 - Larg. 320 - Prof. 200

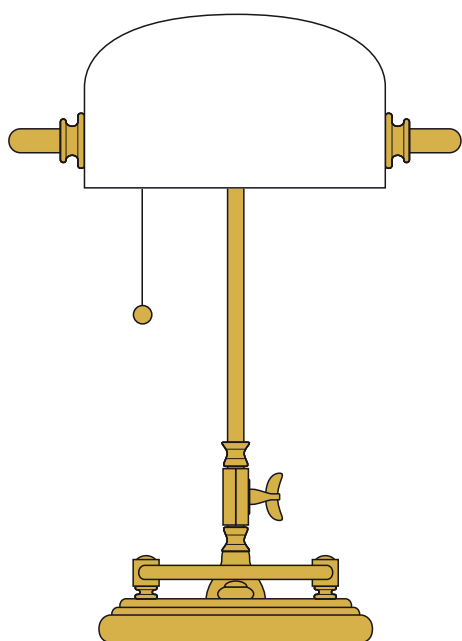

ART. 1503
H. 490 - Larg. 320



IP 20  E 27  Max Watt 100

Finitura ottone
Finition laiton
Brass finishes

.A.D.V.AR



Art. 1500.V.6

Figi



Art. 1503.D.8



Art. 1503.A.6

Aphrodite

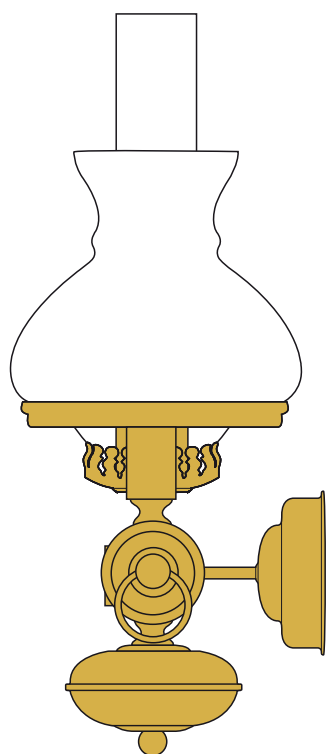

ART. 1443
Vetro Ø 145
H. 320 - Larg. 200 - Prof. 170

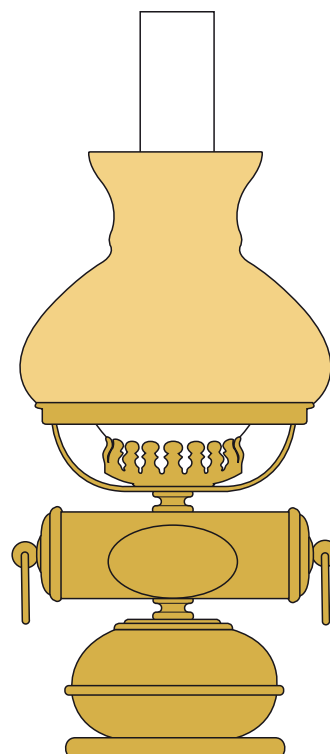

ART. 1446
Vetro Ø 145
H. 350 - Larg. 180

IP 20  E 27  Max Watt 60

Finitura ottone
Finition laiton
Brass finishes

.A.V.AR



Art. 1443.A.6



Art. 1446.V.8

Aphrodite

Aphrodite

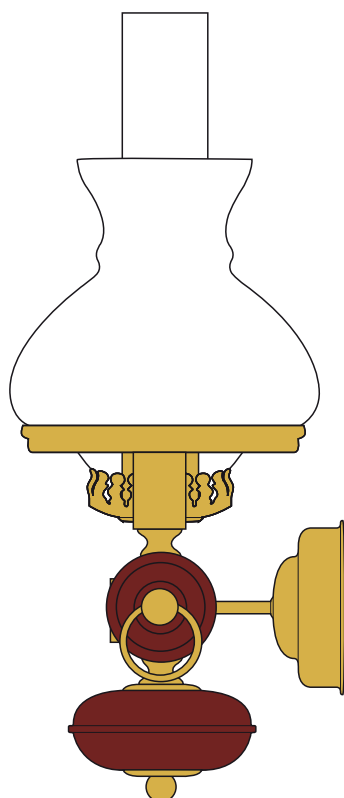

ART. 1451
Vetro Ø 145
H. 320 - Larg. 200 - Prof. 170

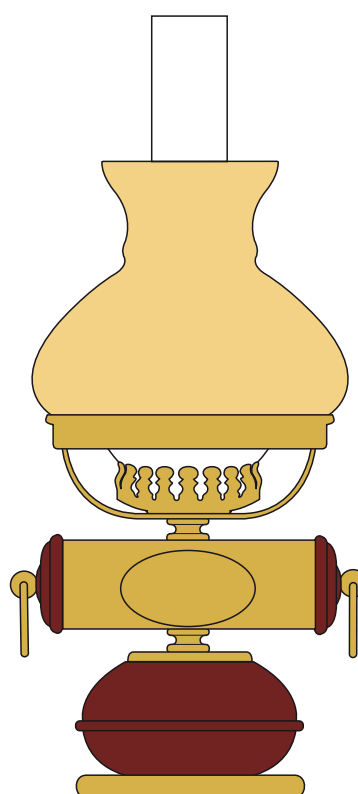

ART. 1450
Vetro Ø 145
H. 350 - Larg. 180

IP 20  E 27  Max Watt 60

Finitura ottone
Finition laiton
Brass finishes

.A.V.AR



Art. 1451.V.6



Art. 1450.V.7

Aphrodite

Aphrodite

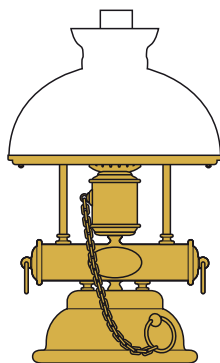

ART. 1440
Vetro Ø 200
H. 480 - Larg. 230

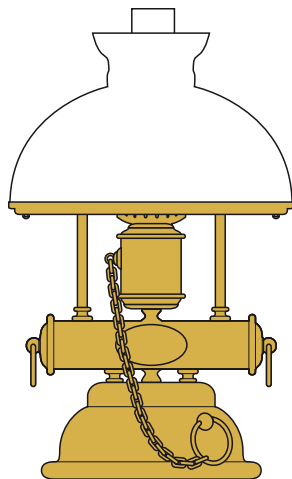

ART. 1441
Vetro Ø 300
H. 520 - Larg. 315

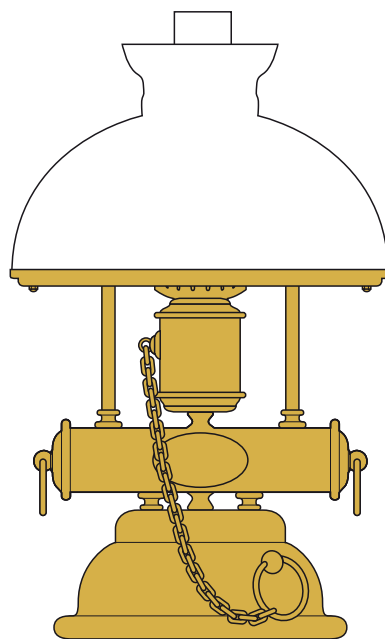

ART. 1442
Vetro Ø 350
H. 560 - Larg. 350

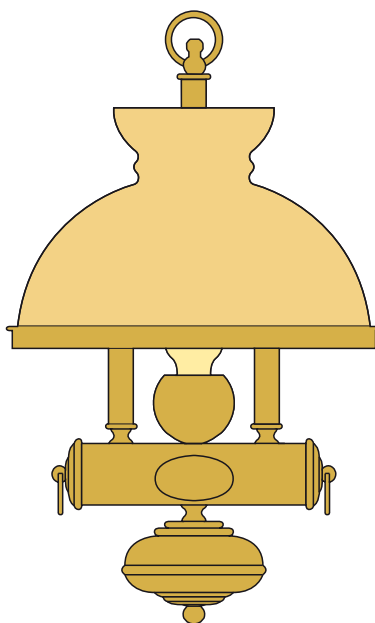

ART. 1444
Vetro Ø 350 - H. 610

IP 20



E 27



Max Watt 100

Finitura ottone
Finition laiton
Brass finishes

.A.V.AR

Aphrodite



Art. 1441.A.6



Art. 1442.V.8



Art. 1444.V.6

Aphrodite

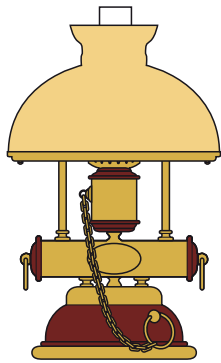

ART. 1448
Vetro Ø 200
H. 480 - Larg. 230

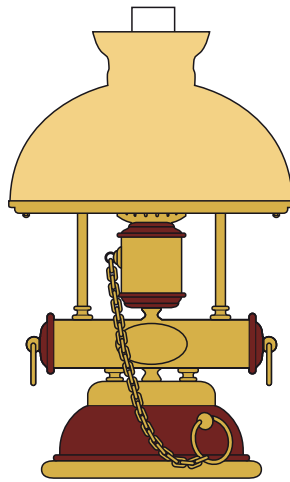

ART. 1449
Vetro Ø 300
H. 520 - Larg. 315

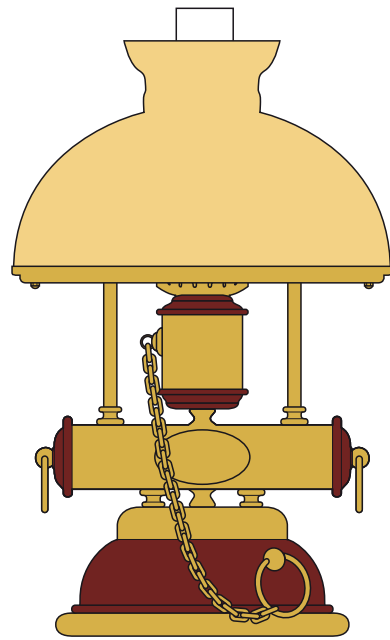

ART. 1453
Vetro Ø 350
H. 560 - Larg. 350

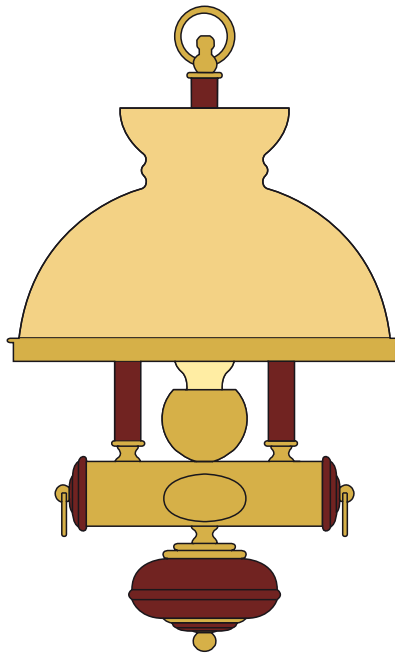

ART. 1452
Vetro OP Ø 350 - H. 610

IP 20  E 27  Max Watt 100

Finitura ottone
Finition laiton
Brass finishes

.A.V.AR



Art. 1453.A.7



Art. 1452.V.7

Aphrodite

Family

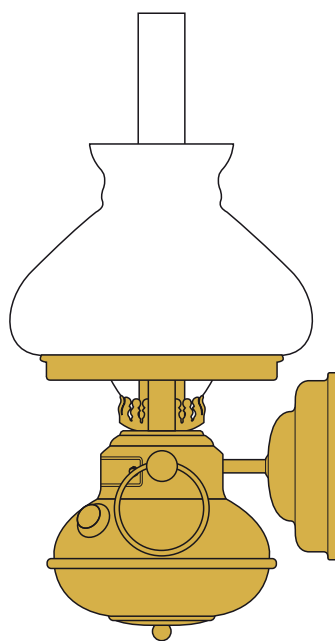

ART. 1137
Vetro Ø 145
H. 400 - Larg. 170 - Prof. 180

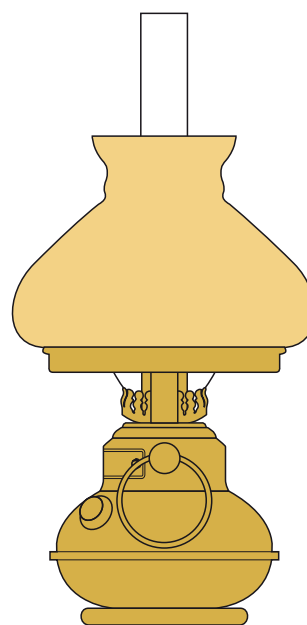

ART. 1138
Vetro Ø 145
H. 420 - Larg. 170

IP 20



E 27



Max Watt 60

Finitura ottone
Finition laiton
Brass finishes

.A.V.AR



Art. 1137.A.6

Family



Family

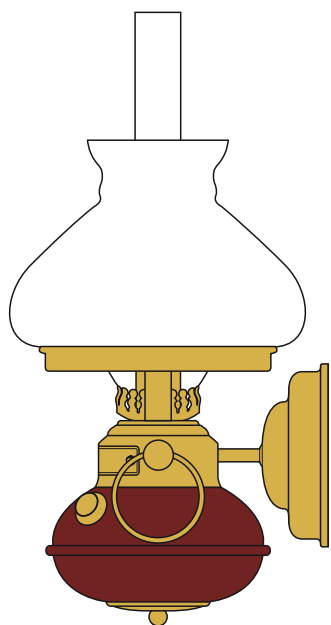

ART. 1141
Vetro Ø 145
H. 400 - Larg. 170 - Prof. 180

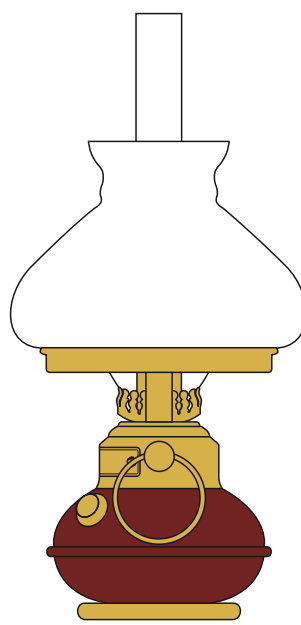

ART. 1142
Vetro Ø 145
H. 420 - Larg. 170

IP 20  E 27  Max Watt 60

Finitura ottone
Finition laiton
Brass finishes

.A.V.AR



Art. 1142.A.7



Art. 1141.V.6

Family



ART. 1705.V - Ø 100 - H. 70

Complementi

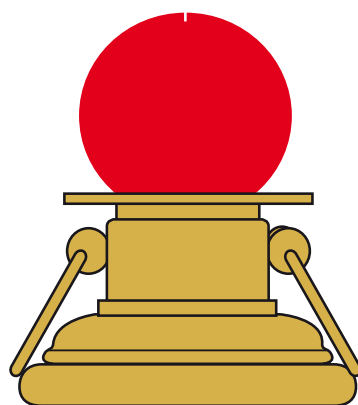

ART. 1704
Ø 100 - H. 70

Finitura ottone
Finition laiton
Brass finishes

.A.V.AR

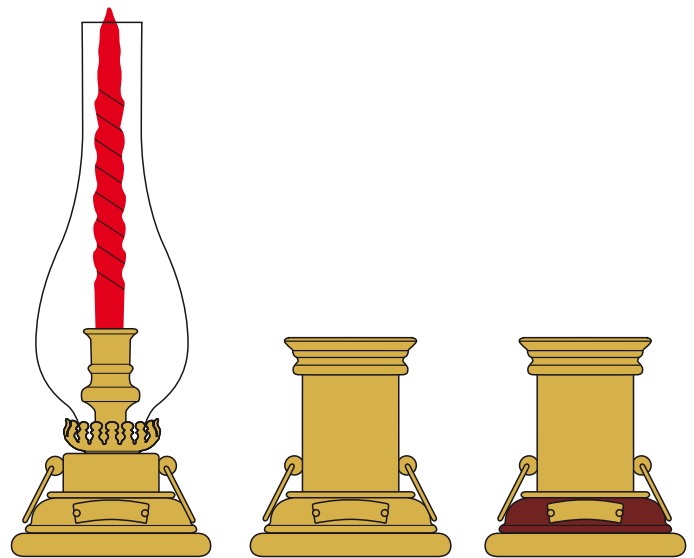

ART. 1703
Ø 120 - H. 335

ART. 1710
Ø 120 - H. 130

ART. 1711
Ø 120 - H. 130

Finitura ottone
Finition laiton
Brass finishes

.A.V.AR

Complementi

ART. 1706.V - Ø 120 - H. 130



ART. 1708
Ø 120 - H. 150



ART. 1707.V
Ø 120 - H. 150

Complementi

Finitura ottone
Finition laiton
Brass finishes

.A.V.AR

®

MORRETTI
LUCE

oblò
hublots
porthole
Bullaugen

SPECCHI / MIROIR / GLASS / SPIEGEL

OROLOGI / HORLOGE / CLOCK / UHREN

TUTTI I NOSTRI OBLÒ SONO TRATTATI
CONTRO L'OSSIDAZIONE AMBIENTALE

TOUS NOS HUBLOTS SONT VERNIS
ANTI- CORROSION

ALL OUR ITEMS ARE TREATED TO
RESISTE TARNISHING

ALLE UNSERE BULLAUGEN SIND GEGEN
UMWELTOXYDATION GESCHÜTZT

Oblò specchio

Serie di oblò da parete, realizzati in ottone, con specchio

Série de hublots muraux, en laiton, avec miroir

A set of porthole, in brass with glass

Reihe von Bullaugen für die Wand, aus Messing, mit Spiegel.

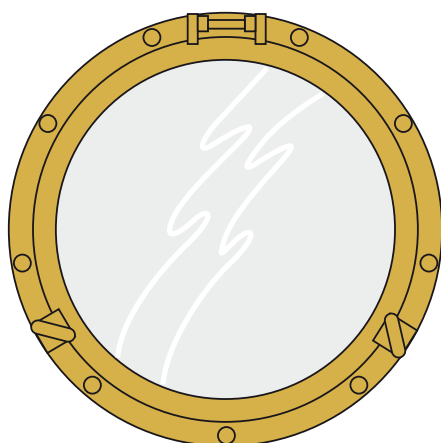

ART. 100.02 - Ø 20

ART. 100.03 - Ø 25

ART. 100.04 - Ø 30

ART. 100.06 - Ø 37

ART. 100.05 - Ø 47

A richiesta finiture ottone .AR

Finitura ottone
Finition laiton
Brass finishes

.A.V.AR



Oblò specchio

Oblò ottone

Serie di oblò da parete, realizzata in ottone, comprendente orologi automatici con numeri romani e barometri.

Série de hublots muraux, en laiton, comprenant des horloges automatiques en chiffres romains

OROLOGI - HORLOGES
CLOCKS - UHREN

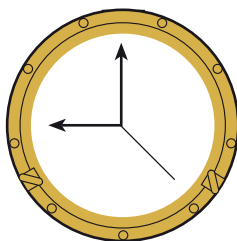

ART. 100.08
Ø 20

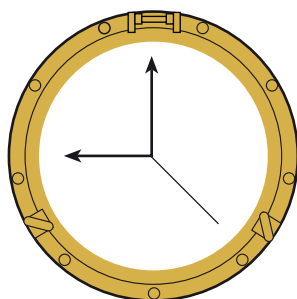

ART. 100.10 - Ø 25
ART. 100.11 - Ø 30

A set of porthole, in brass with clock

Reihe von Bullaugen für die Wand, aus Messing, mit automatischen Uhren mit römischen Zahlen

A richiesta finiture ottone .AR

ART. 100.10.AR



ART. 100.08



ART. 100.10



Oblò ottone

Oblò legno

Serie di oblò da parete, realizzata in legno e ottone comprendente orologi automatici con numeri romani, e specchi.

Série de hublots muraux, en bois et laiton, comprenant des horloges automatiques en chiffres romains, et des miroirs

SPECCHI - MIROIRS
GLASS - SPIEGEL

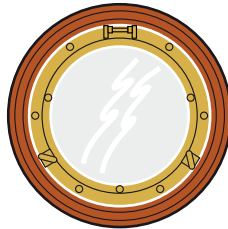

ART. 100.16
Ø 25,5

OROLOGI - HORLOGES
CLOCKS - UHREN

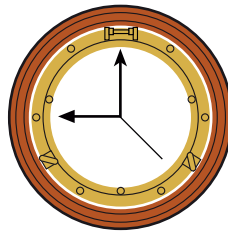

ART. 100.18
Ø 25,5

A set of porthole, in brass and wood with clock and glass

Reihe von Bullaugen für die Wand, aus Holz und Messing, mit
automatischer Uhr en mit römischen Zahlen und Spiegel

A richiesta finiture ottone .AR



ART. 100.16



ART. 100.18

Oblò legno

Oblò legno

Serie di oblò da parete, realizzata in legno e ottone comprendente orologi automatici con numeri romani e specchi.

Série de hublots muraux, en bois et laiton, comprenant des horloges automatiques en chiffres romains, des miroirs

SPECCHI - MIROIRS
GLASS - SPIEGEL

OROLOGI - HORLOGES
CLOCKS - UHREN

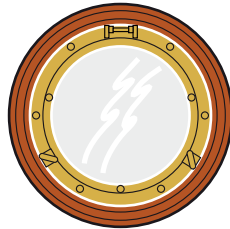

ART. 200.01
Ø 30

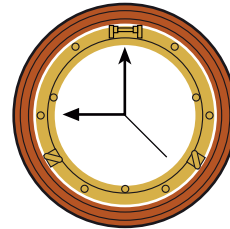

ART. 200.02
Ø 30

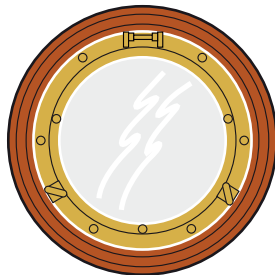

ART. 200.04
Ø 36

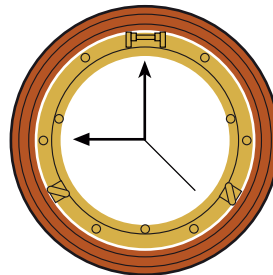

ART. 200.06
Ø 36

A set of porthole, in brass and wood with clock, and glass

Reihe von Bullaugen für die Wand, aus Holz und Messing, mit automatischeh Uhr

A richiesta finiture ottone .AR

ART. 200.02



ART. 200.01



Oblò legno

Campana

Campana di bordo in ottone lucido con attacco oscillante
Cloche de bord en laiton brillant avec fixation oscillante

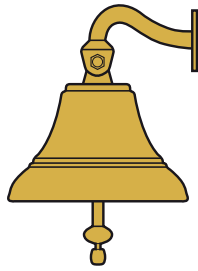

ART. 151
Ø 10,5

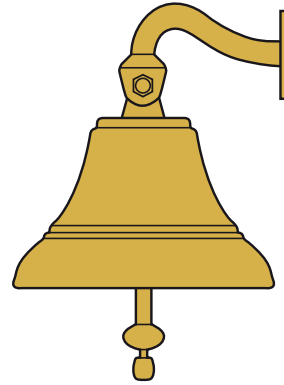

ART. 152
Ø 15

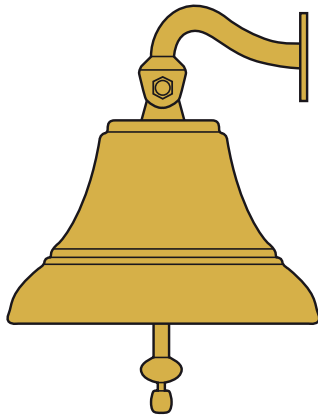

ART. 153
Ø 18

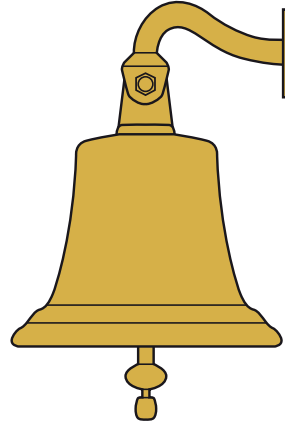

ART. 155
Ø 16

Ship's Bell in polished brass complete with bracket
Schiffsglocke aus Hochglanzmessing mit Schwing-Aufhängung

A richiesta finiture ottone .AR

ART. 153.AR

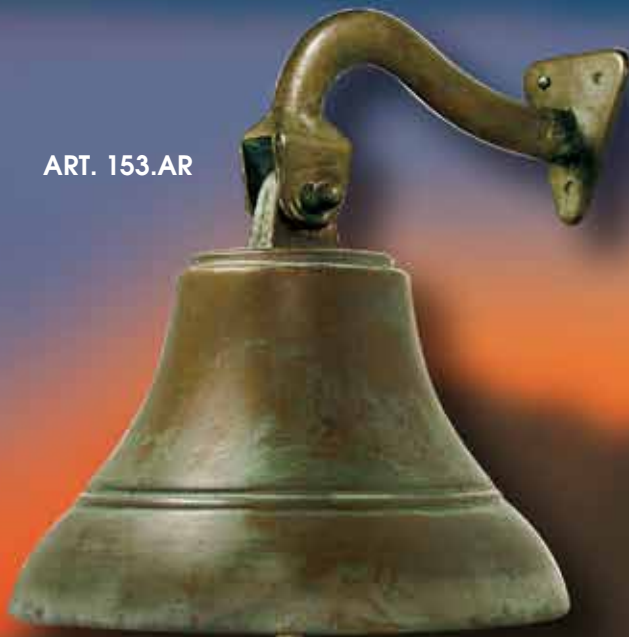

ART. 155.AR

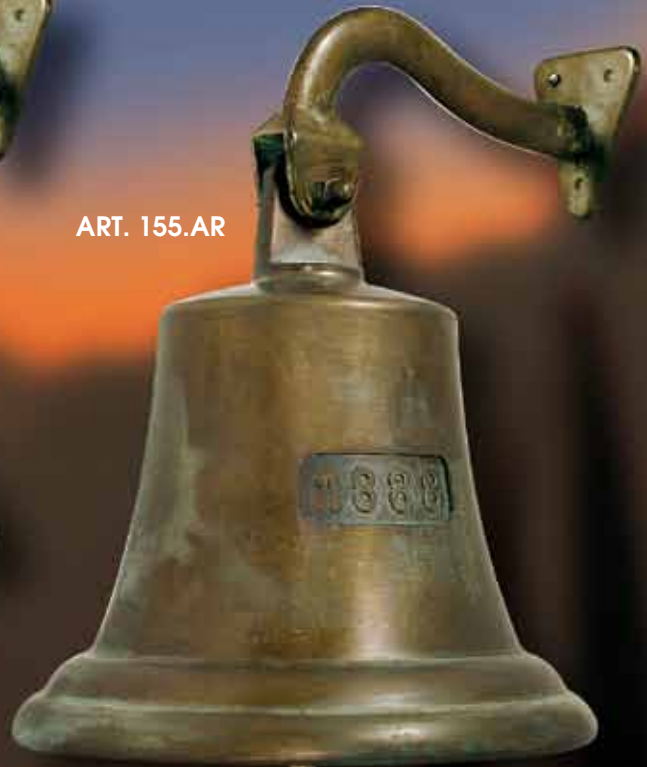

ART. 153



ART. 155

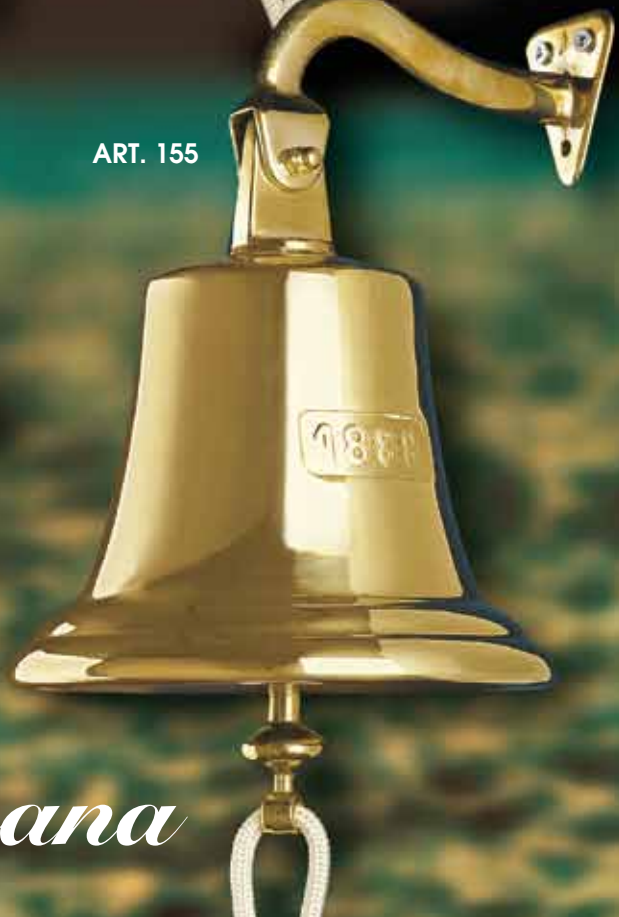

Campana

LEGENDA DEI SIMBOLI



Certifica che il prodotto risponde ai requisiti essenziali di sicurezza e che può circolare liberamente all'interno della Comunità Europea.



Simbolo di terra che appare sugli apparecchi di classe prima per indicare che dispongono solo dell'isolamento funzionale. Deve essere utilizzato l'apposito morsetto per il collegamento a terra.



Apparecchio di classe seconda (doppio isolamento). Indica che l'apparecchio è doppiamente protetto contro il contatto accidentale con parti in tensione da parte dell'utilizzatore. Esclude e vieta la messa a terra.



Apparecchio di classe terza. Utilizza tensione inferiore a 50 volts. Esclude e vieta la messa a terra.



Simbolo utilizzato per gli apparecchi idonei all'installazione su superfici normalmente infiammabili (temperatura sulla base d'appoggio max. 90°C.).



Apparecchi non idonei all'installazione su superfici normalmente infiammabili.



Il prefisso IP (International Protection) seguito da due cifre indica la resistenza dell'apparecchio alla penetrazione di solidi e liquidi. Prima cifra: contro la penetrazione dei corpi solidi e il contatto con elementi in tensione; seconda cifra: contro la penetrazione dei liquidi.



Simbolo che indica la protezione dell'apparecchio contro la pioggia.



Simbolo che indica la protezione dell'apparecchio contro gli spruzzi d'acqua.



Simbolo che indica la protezione dell'apparecchio contro i getti d'acqua provenienti da tutte le direzioni.



Simbolo che indica la protezione dell'apparecchio contro la polvere.

GRADO DI PROTEZIONE DEGLI APPARECCHI

IP 20

- (2) Protezione contro la penetrazione di corpi solidi con dimensioni superiori a \varnothing 12 mm.
 - (0) Nessuna protezione contro la pioggia.
-

IP 23

- (2) Protezione contro la penetrazione di corpi solidi con dimensioni superiori a \varnothing 12 mm.
 - (3) Protezione contro la pioggia con caduta fino a 60° di inclinazione.
-

IP 43

- (4) Protezione contro la penetrazione di corpi solidi con dimensioni superiori a \varnothing 1 mm.
 - (3) Protezione contro la pioggia.
-

IP 44

- (4) Protezione contro la penetrazione di corpi solidi con dimensioni superiori a \varnothing 1 mm.
 - (4) Protezione contro gli spruzzi d'acqua.
-

IP 54

- (5) Protezione contro la polvere.
 - (4) Protezione contro gli spruzzi d'acqua.
-

IP 55

- (5) Protezione contro la polvere.
 - (5) Protezione contro i getti d'acqua da tutte le direzioni.
-

IP 65

Stagno alla penetrazione della polvere e protetto contro i getti d'acqua

IP 67

Stagno alla penetrazione della polvere e protetto contro gli effetti delle ondate