

—
Balloons
Shadows
Muffins
Memory
Capsula
Mona
Whistle
—

BROOKIS

BROKIS
DESIGN BY
LUCIE KOLDOVA
DAN YEFFET
BORIS KLIMEK



BALLOONS

— A collection of simple yet timeless lamps based on a transparent, nearly invisible balloon with a hovering reflector to serve as an elegant and stately source of light in any setting. The clean appearance of the transparent balloons is underlined by the natural beauty of the quality hand-blown glass. The collection features a small table model and two free-standing models. The size of the largest Balloon shade is the embodiment of exceptional glassblowing craftsmanship, as it pushes the technique to its very limits. —



COLOUR

GLASS/ALL

- (CGS U66 glossy)
- CGC 23 transparent
- CGC 516 smoke grey
- CGC 538 smoke brown

SPOTLIGHT/BAS

- CCS 575 white
- CCS 582 black
- CCS 613 lemon yellow
- CCS 574 reflective orange
- CCS 583 gold

SPOTLIGHT/ADD

- CCS 584 copper
- CCS 69 brass
- CCS 275 chrome

TEXTILE CABLES/ALL

- CECL 521 white
- CECL 606 yellow
- CECL 530 red
- CECL 520 grey
- CECL 519 black









Paying homage to its typological heritage, the Shadows collection is a new take on the recognized and timeless French atelier pendant spot light. The five-lamp clusters feature different types of glass shade that slide over a wooden neck. The variable fittings allow you to apply your own creativity in composing new lighting experiences every day, while the purity of form is underscored by the hidden light source – a warm LED spotlight.

SHADOWS





COLOUR

GLASS /BAS

(CGS U66 glossy, CGSU 67 acid-etched)
CGC 39 triplex opal

GLASS /STA

(CGS U66 glossy, CGSU 67 acid-etched)
CGC 516 smoke grey
CGC 538 smoke brown
CGC 36 black - triplex opal
CGC 602 black - transparent
CGC 38 opaline
CGC 23 transparent

TEXTILE CABLES /ALL

CECL 521 white
CECL 606 yellow
CECL 530 red
CECL 520 grey
CECL 519 black

SURFACE /BAS

CCS 518 European oak natural waxed
CCS 657 European oak un-treated
CCS 592 European oak tinted black









Muffin lamps convey a truly extraordinary lighting experience. Their puffy, round shapes and combination of traditional hand-blown tinted glass, oak, and gentle light fill any space with a special aura. The singular design and exceptional quality of the Muffin lamps caught the attention of Yves Saint Lorraine, which used them in a TV advertisement for its 2011 men's collection. The Muffin collection comprises three basic variants – floor, ceiling, and table – that can be fitted with a wooden shade as well as different glass shades in subtle tones of grey, brown, violet etc.

MUFFINS



COLOUR

GLASS / BAS

- (CGS U66 glossy)
- CGC 23 transparent
- CGC 540 cognac
- CGC 515 amber
- CGC 554 violet - transparent
- CGC 516 smoke grey
- CGC 538 smoke brown
- CGC 38 opaline
- CGC 39 triplex opal

TEXTILE CABLES / ALL

- CECL 521 white
- CECL 606 yellow
- CECL 530 red
- CECL 520 grey
- CECL 519 black

SURFACE / BAS

- CCS 518 European oak natural waxed
- CCS 657 European oak un-treated

SURFACE / STA

- CCS 592 European oak tinted black

SURFACE / ADD

- CCS 680 European oak tinted white

SURFACE / IND

- CCS 757 American walnut









MEMORY

Playful, amusing, surprising – the Memory collection of ceiling and wall fixtures kindles the imagination and takes the beholder back to the carefree days of childhood. Three sizes and a range of colors allow you to turn your creativity loose in devising various lighting experiences. With the hanging strings serving to switch the lights on and off, there is nothing to interrupt the illusion of real balloons. This is beauty in its simplest and most effective form.



COLOUR

GLASS/BAS
(CGS U66 glossy, CGSU 67 acid-etched)
CGC 33 triplex opal
CGC 47 yellow - triplex opal
CGC 30 light pink - triplex opal
CGC 580 orange - triplex opal
CGC 579 red - triplex opal
CGC 578 green apple - triplex opal
CGC 601 turquoise - triplex opal
CGC 28 blue - triplex opal
CGC 617 grey - triplex opal



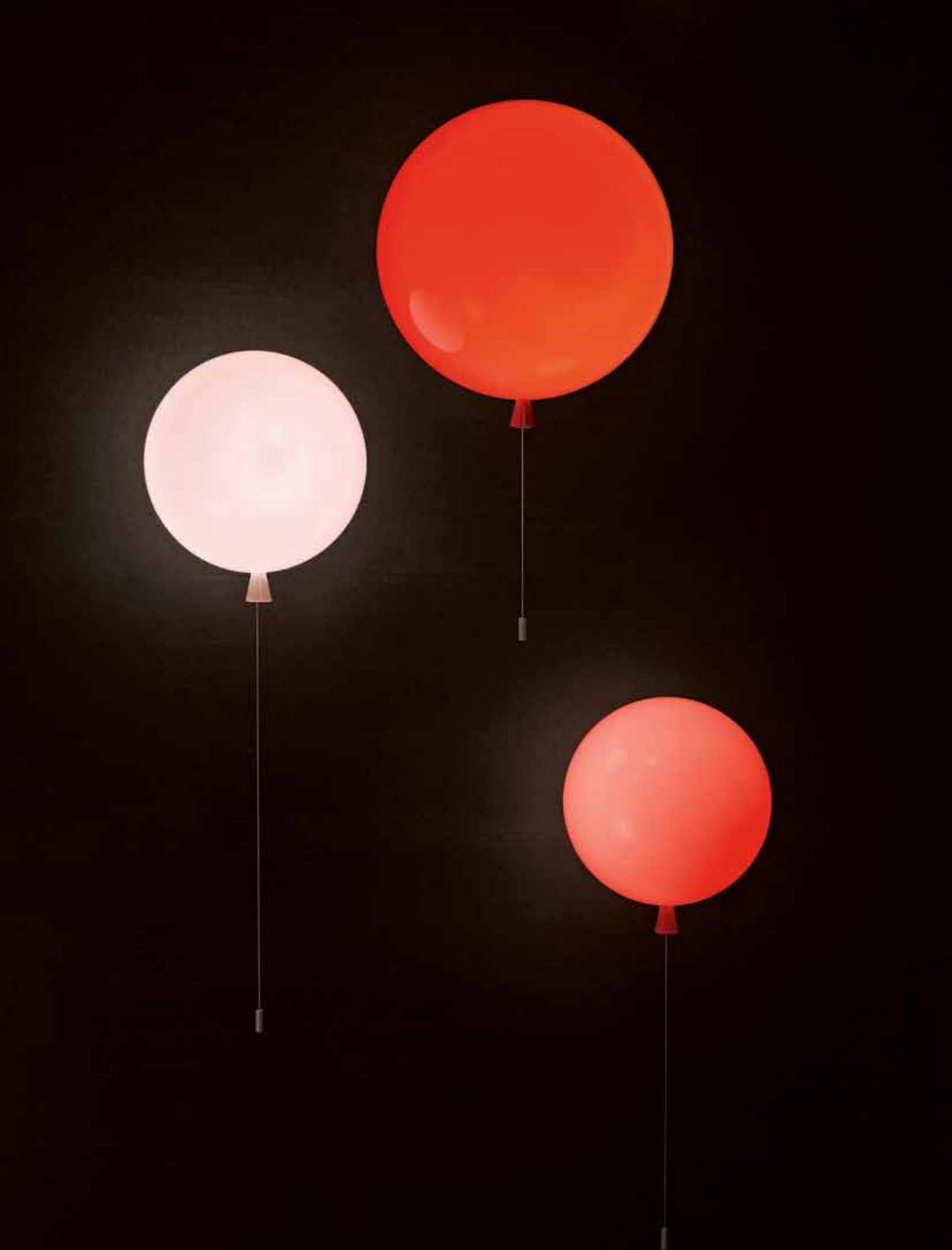



The Capsula model is a brilliant pendant light design composed of two convex capsules, one overlapping the other and fusing into a singular form. The design resembles cells or plant seeds and evokes the metaphor of light as the source of life. The combination of a crystal-clear glass outer shell and an internal capsule of colored glass gives rise to an exciting 3D optical effect, while the tubular LED light source casts soft and gentle illumination throughout any interior.

CAPSULA

COLOUR

GLASS/ALL

top parts / CGSU 66 glossy
CGC 23 transparent
CGC 516 smoke grey
CGSU 66 glossy
inside parts / CGSU 66 glossy, CGSU 67 acid-etched
CGCI 682 transparent
CGCI 681 transparent - yellow
CGCI 683 violet - transparent
CGCI 684 dark smoke grey
CGCI 685 smoke grey
CGCI 686 amber
CGCI 749 opaline

TEXTILE CABLES/ALL

CECL 519 black

SURFACE/ALL

CCS 592 European oak tinted black



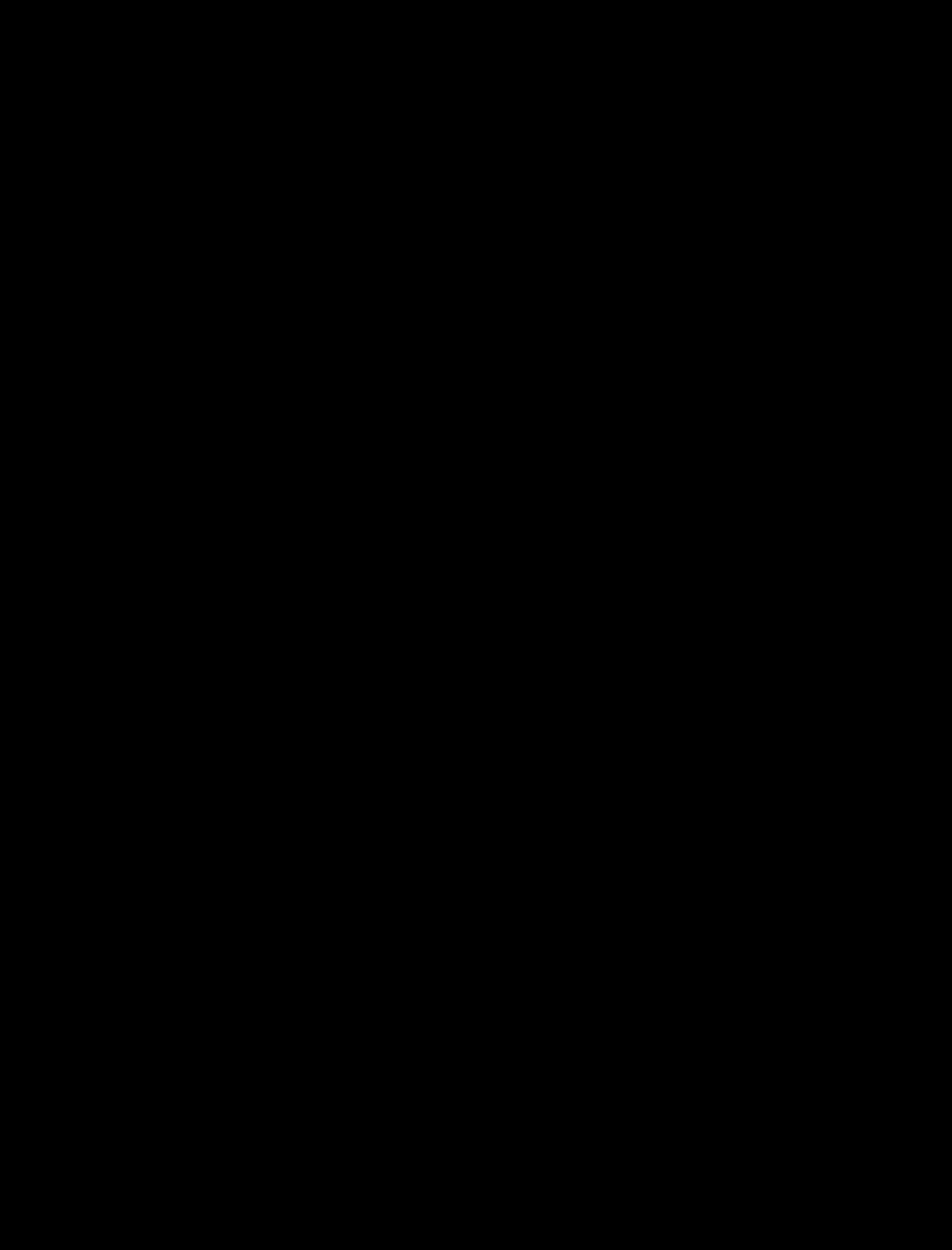





Futuristic bell-shaped Mona lamp demonstrates sensitively the beauty of smooth glass in soft curves. Tubular light source dramatically cuts through the delicate body of the piece and illuminates the design's thrilling tension. The artist's distinctive style is reflected in the unexpected combination of wood, textile, and blown glass. Whilst the sophisticated design of this elegant hand blown lampshade, resembling form of a futuristic helmet, is based on the principle of penetrating forms, previously applied in the design of the Capsula light (Brokis, 2013). The glass shade and textile suspension straps are affixed to the LED light source with a pair of elegant wooden buttons.

MONA



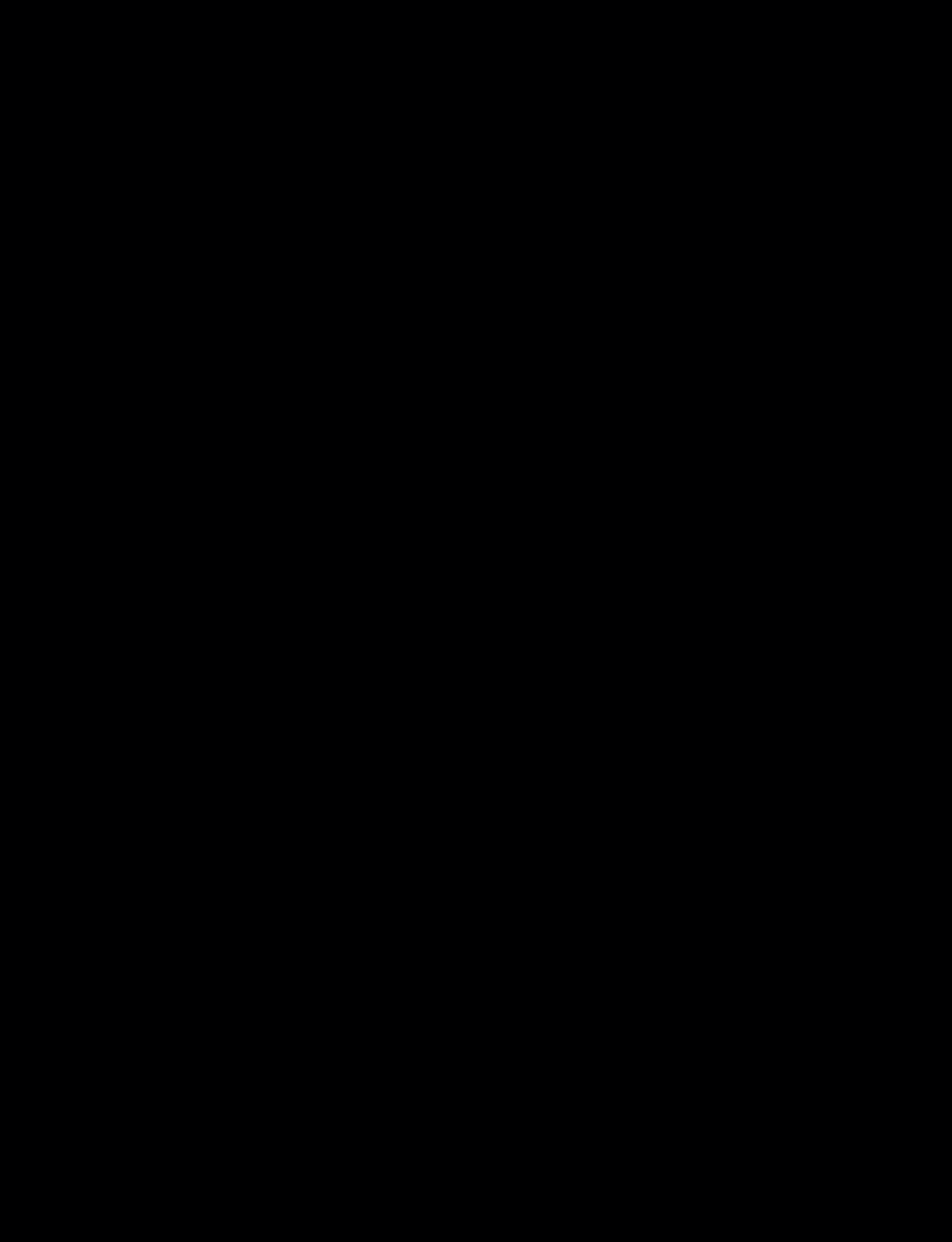



COLOUR

GLASS/ALL

(CGSU 66 glossy)
CGC 602 black - transparent
CGC 554 violet - transparent
CGC 38 opaline
CGC 516 smoke grey
CGC 23 transparent

SURFACE/ALL

CCS 680 European Oak - tinted white
CCS 592 European Oak - tinted black
CCS 732 Aluminium base - white
CCS 727 Aluminium base - black
CCS 734 Aluminium tube - white
CCS 733 Aluminium tube - black
CCS 518 European Oak - natural waxed*
CCS 657 European Oak - untreated*

TEXTILE CABLES/BAS*

CCS 679 textile straps - white
CCS 678 textile straps - black

TEXTILE CABLES/ADD*

CCS 758 leather straps - white
CCS 761 leather straps - black

* only for MONA Pendant



WHISTLE

Suspension Whistle lamp constitutes a symbiosis of two different forms or their multiplication. As the external shape is following the ray of light, it symbolically portrays the shape of traditional whistles. Inserted spot lamp is highlighted by offset inks, outer form creates an impression of the shade of an internal soul of the pendant and further define the precise shape of elongated pipes. Hand-blown objects create a visual line of archetypal lights directing light downwards. Whistle lamp collection consists of three glass pipes of larger dimensions and showcases the mastery of the material and the Czech glassmakers.







COLOUR

GLASS/BAS
(CGS U66 glossy)
CGC 538 smoke brown
CGC 516 smoke grey
CGC 23 transparent

TEXTILE CABLES /BAS
CECL 521 white
CECL 519 black
CECL 726 magenta
CECL 725 menthol
CECL 520 grey

SPOTLIGHT /BAS
CCS 575 white
CCS 582 black
CCS 724 magenta
CCS 723 menthol
CCS 720 grey

SPOTLIGHT /ADD
CCS 584 copper
CCS 69 brass
CCS 275 chrome





BALLOONS

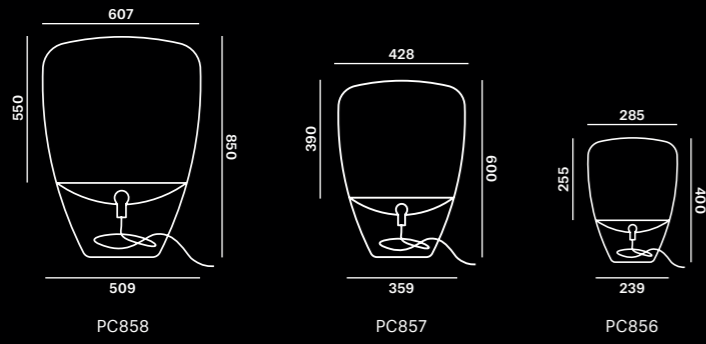

SHADOWS

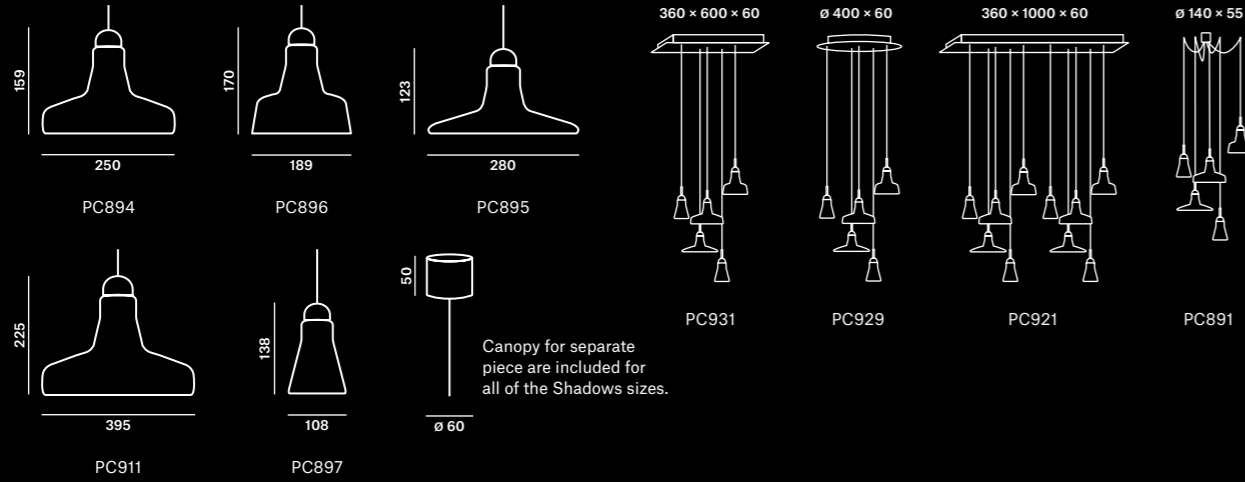

MUFFINS

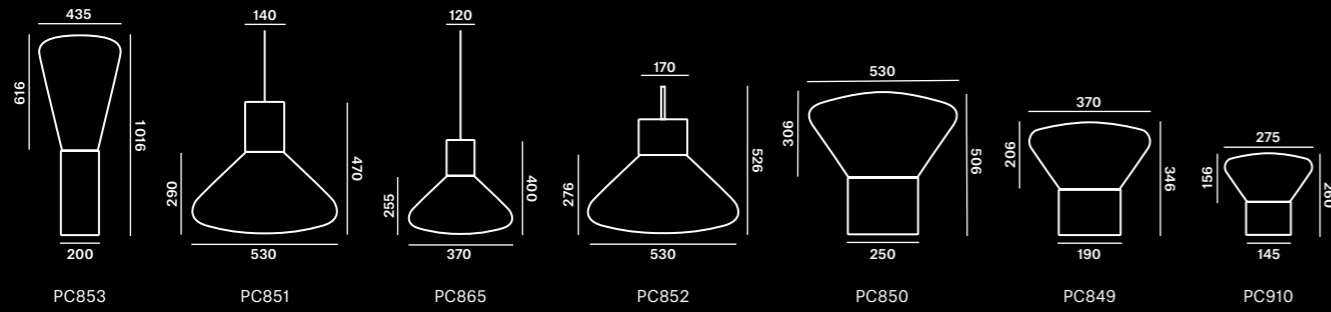

MEMORY

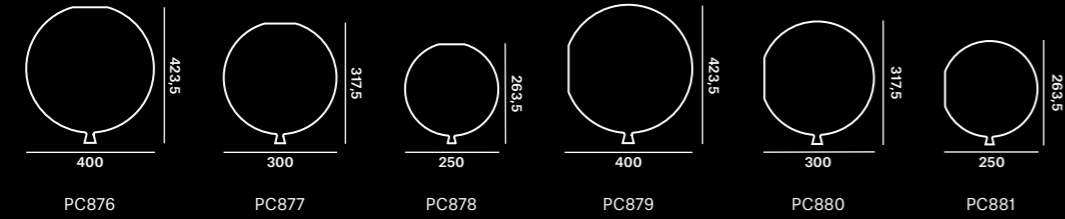

CAPSULA

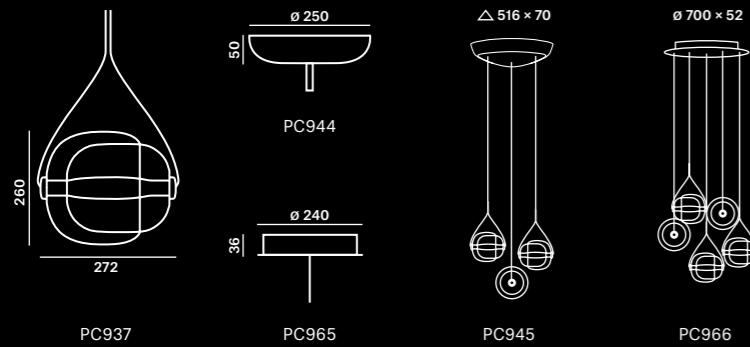

MONA

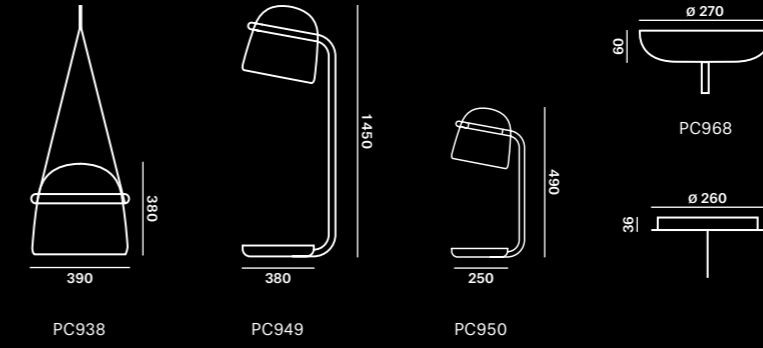

WHISTLE

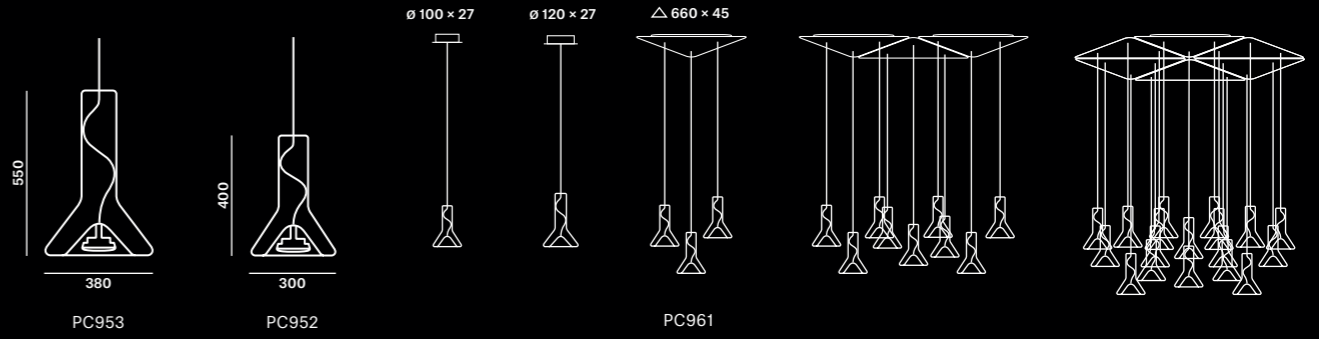

The product variants that we offer are classified in ascending order into four price levels: Basic (BAS), Standard (STA), Advanced (ADD), Individual (IND). Product variants classified as ALL are universal and may be selected for any of the four price levels.

DESIGNERS
Lucie Koldova
Dan Yeffiet
Boris Klimek

PHOTO
Martin Chum

GRAPHIC DESIGN
Studio Marvil

BROKIS

OFFICE Španielova 1315/25
163 00 Prague 6, Czech Republic
SHOWROOM Sídlíště Janštejn 39
588 52 Horní Dubenky
Czech Republic
T +420 567 211 517
F +420 567 211 727
E order@brokis.cz
W www.brokis.cz

PRODUCT DESIGN
Creative direction
Lucie Koldova



BROKIS

